

CANTILEVER SE 4.0

CANTILEVER HARDWARE

CANTILEVER SE						
	mm; kg	mm; kg	mm; kg	mm; kg	mm; kg	mm; kg
A	3000	3200	3400	3600	3800	4000
max. weight gate	325 kg	325 kg	325 kg	325 kg	325 kg	325 kg
B	900	960	1020	1080	1140	1200
C	1300	1360	1420	1480	1540	1600
D	270	270	270	270	270	270
F	130	130	130	130	130	130



EASY
ASSEMBLY



FAST
NO WELDING
REQUIRED



15 BOLTS
15 RIVET NUTS
INCLUDED (*)



«C» TRACK SERIAL NO.
100% COMPATIBILITY
CARRIAGE TESTED



GERMAN
STEEL



270
g/m²
HOT DIPPED
GALVANIZED



ARROW STRAIGHT
«C» TRACK



SLOTTED HOLE
PUNCHED EVERY
400mm IN TRACK



GALVANIZED
INTERNAL EDGES



MADE IN
CZECH REPUBLIC



C 2
HIGH QUALITY
BEARINGS



CARRIAGES CENTER
HOLES MILLED
NOT LASER CUT



MULTI RIVETED
SECTIONS



JAPANESE ROBOTICS
FANUC



UNIVERSITY OF
TECHNOLOGY – BRNO



- 37°C
TESTED & PROVEN



+ 50°C
TESTED & PROVEN



NO WELDING
REQUIRED

(*) ONLY SETS

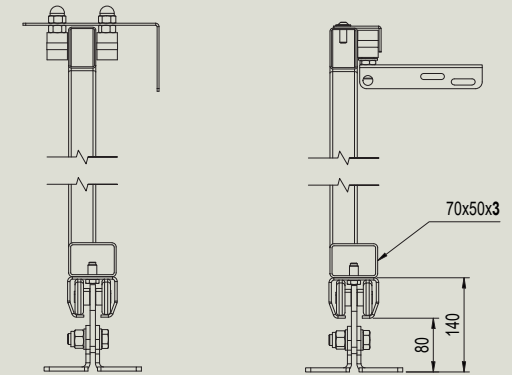
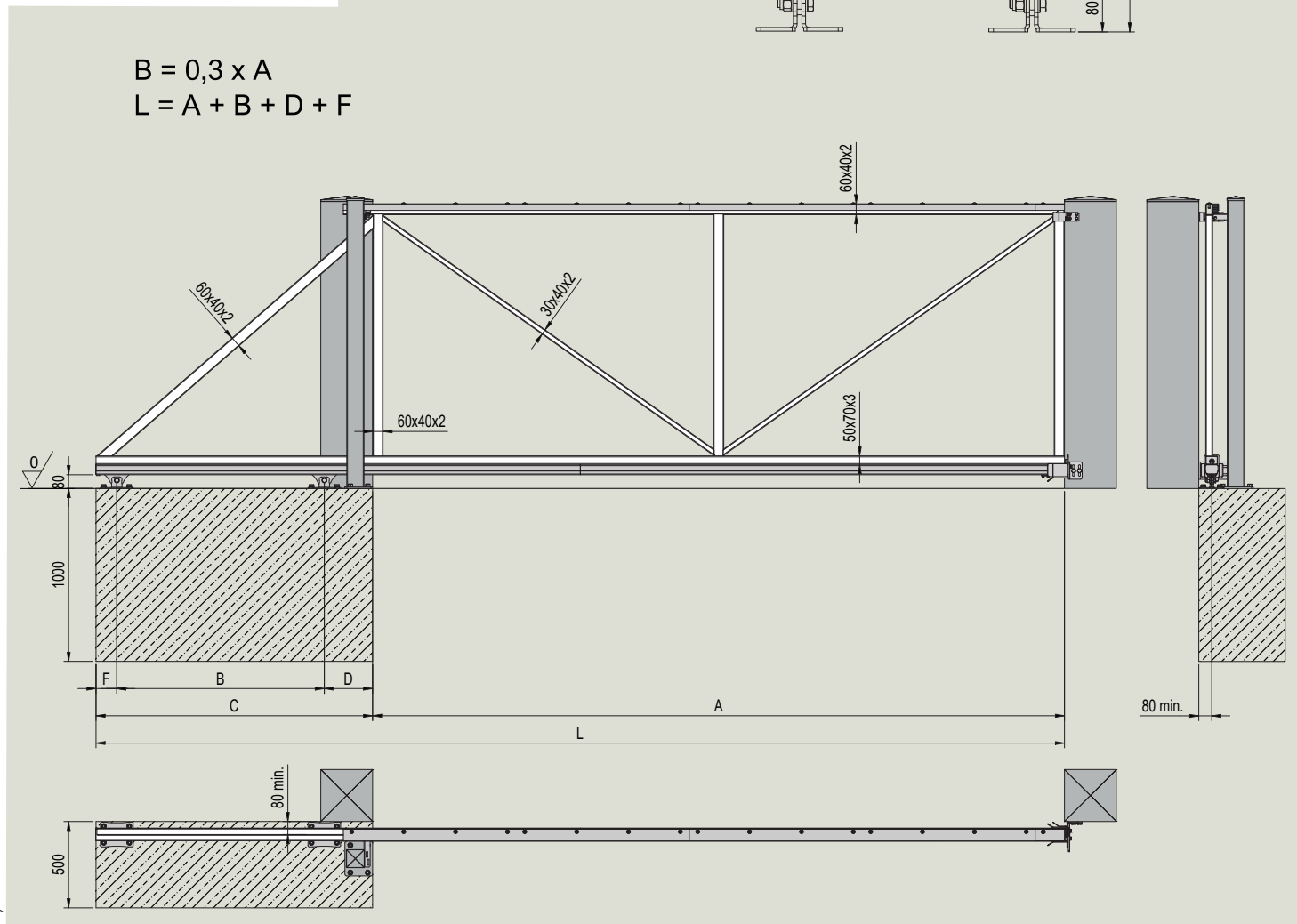

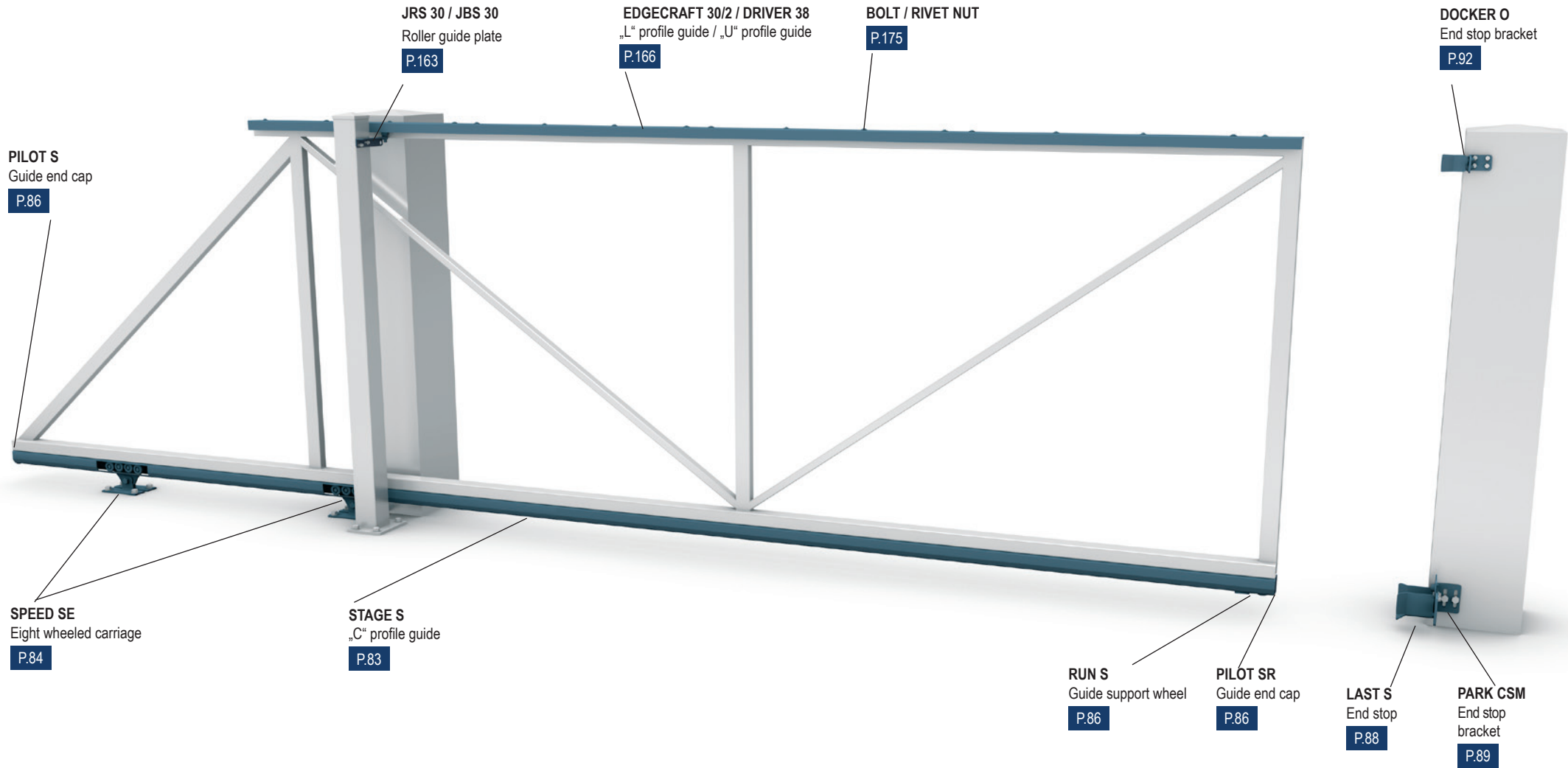



















CANTILEVER S 4.5

CANTILEVER HARDWARE

CANTILEVER S	mm; kg	mm; kg	mm; kg	mm; kg	mm; kg	mm; kg	mm; kg	mm; kg
A	3000	3200	3400	3600	3800	4000	4200	4500
max. weight gate	325 kg	325 kg	325 kg	350 kg	375 kg	400 kg	425 kg	450 kg
B	900	960	1020	1080	1140	1200	1260	1350
C	1440	1500	1560	1620	1680	1740	1800	1890
D	270	270	270	270	270	270	270	270

-  EASY ASSEMBLY
-  FAST NO WELDING REQUIRED
-  15 BOLTS 15 RIVET NUTS INCLUDED (*)
-  «C» TRACK SERIAL NO. 100% COMPATIBILITY CARRIAGE TESTED
-  GERMAN STEEL
-  HOT DIPPED GALVANIZED
-  ARROW STRAIGHT «C» TRACK
-  SLOTTED HOLE PUNCHED EVERY 400mm IN TRACK
-  GALVANIZED INTERNAL EDGES
-  MADE IN CZECH REPUBLIC
-  C 2 HIGH QUALITY BEARINGS
-  CARRIAGES CENTER HOLES MILLED NOT LASER CUT
-  MULTI RIVETED SECTIONS
-  JAPANESE ROBOTICS FANUC
-  UNIVERSITY OF TECHNOLOGY – BRNO
-  - 37°C TESTED & PROVEN
-  + 50°C TESTED & PROVEN
-  NO WELDING REQUIRED

$$B = 0,3 \times A$$

$$L = A + B + (2 \times D) + E$$

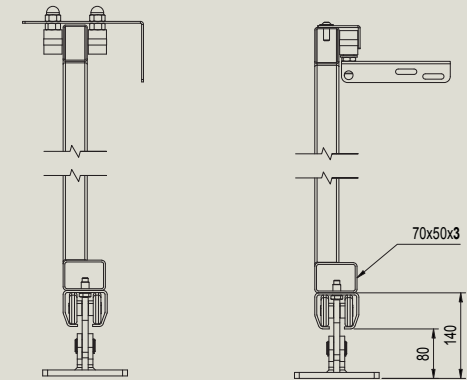
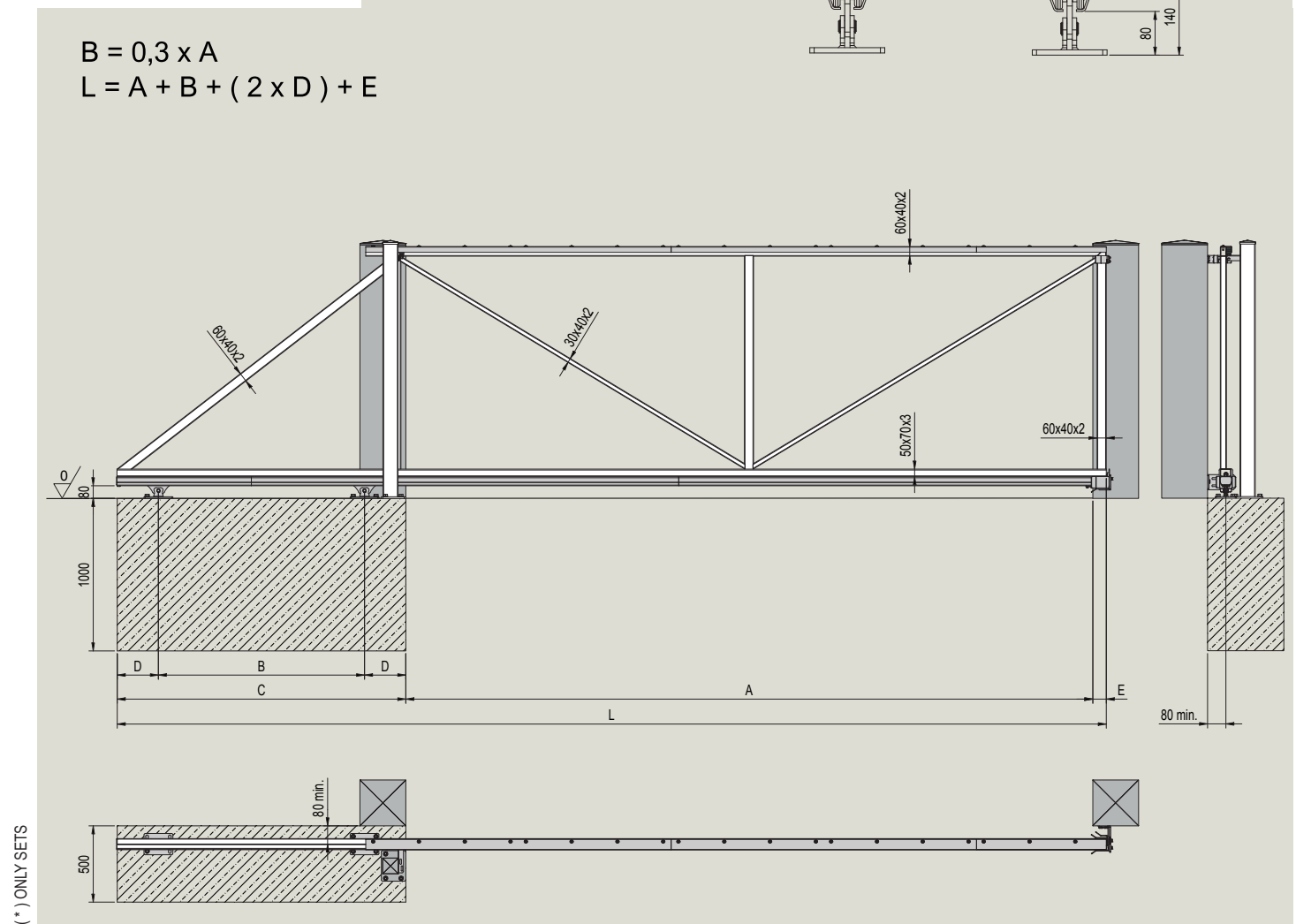

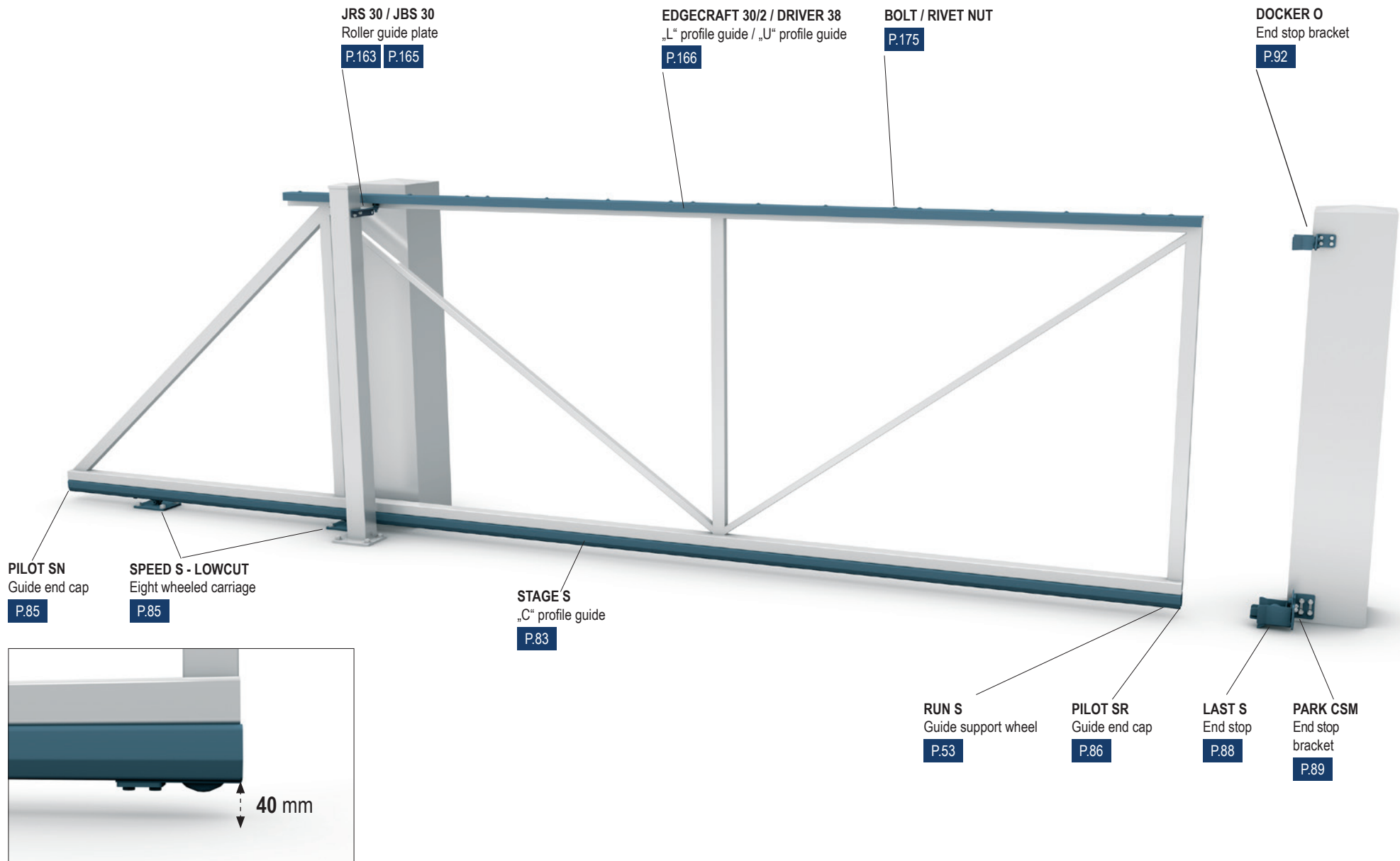

NEW 

CAIS **CANTILEVER LOWCUT 4.0**

40 MM LOW HEIGHT
CANTILEVER HARDWARE

LOWCUT 4.0						
	mm; kg	mm; kg	mm; kg	mm; kg	mm; kg	mm; kg
A	3000	3200	3400	3600	3800	4000
max. weight gate	240 kg	240 kg	240 kg	240 kg	240 kg	240 kg
B	900	960	1020	1080	1140	1200
C	1300	1360	1420	1480	1540	1600
D	270	270	270	270	270	270
F	130	130	130	130	130	130



40 MM LOW HEIGHT
"C" TRACK



C 2
HIGH QUALITY
BEARINGS



EASY
ASSEMBLY



CARRIAGES CENTER
HOLES MILLED
NOT LASER CUT



FAST
NO WELDING
REQUIRED



MULTI RIVETED
SECTIONS



15 BOLTS
15 RIVET NUTS
INCLUDED (*)



JPN
JAPANESE ROBOTICS
FANUC



«C» TRACK SERIAL NO.
100% COMPATIBILITY
CARRIAGE TESTED



R&D
UNIVERSITY OF
TECHNOLOGY - BRNO



GERMAN
STEEL



- 37°C
TESTED & PROVEN



270
g/m²
HOT DIPPED
GALVANIZED



+ 50°C
TESTED & PROVEN



ARROW STRAIGHT
«C» TRACK



NO WELDING
REQUIRED



SLOTTED HOLE
PUNCHED EVERY
400mm IN TRACK



MADE IN
CZECH REPUBLIC

SPEED S - LOWCUT

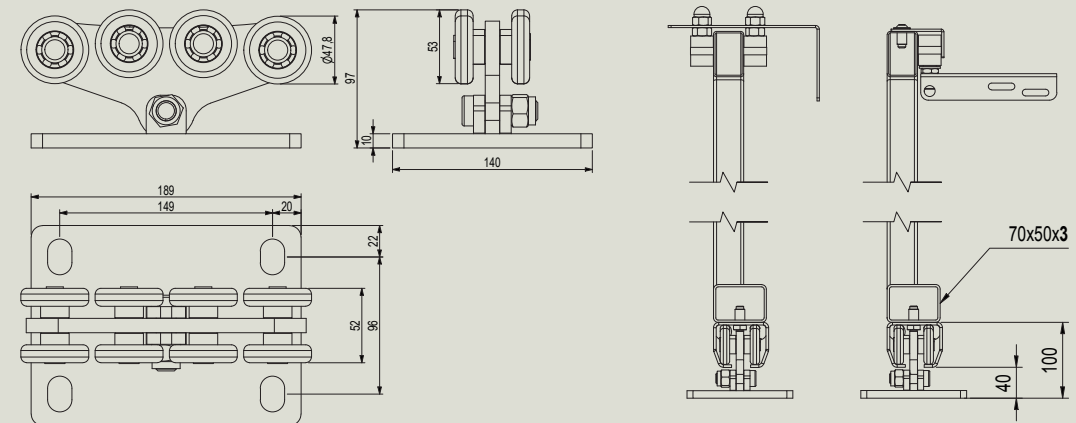

DETAIL: A

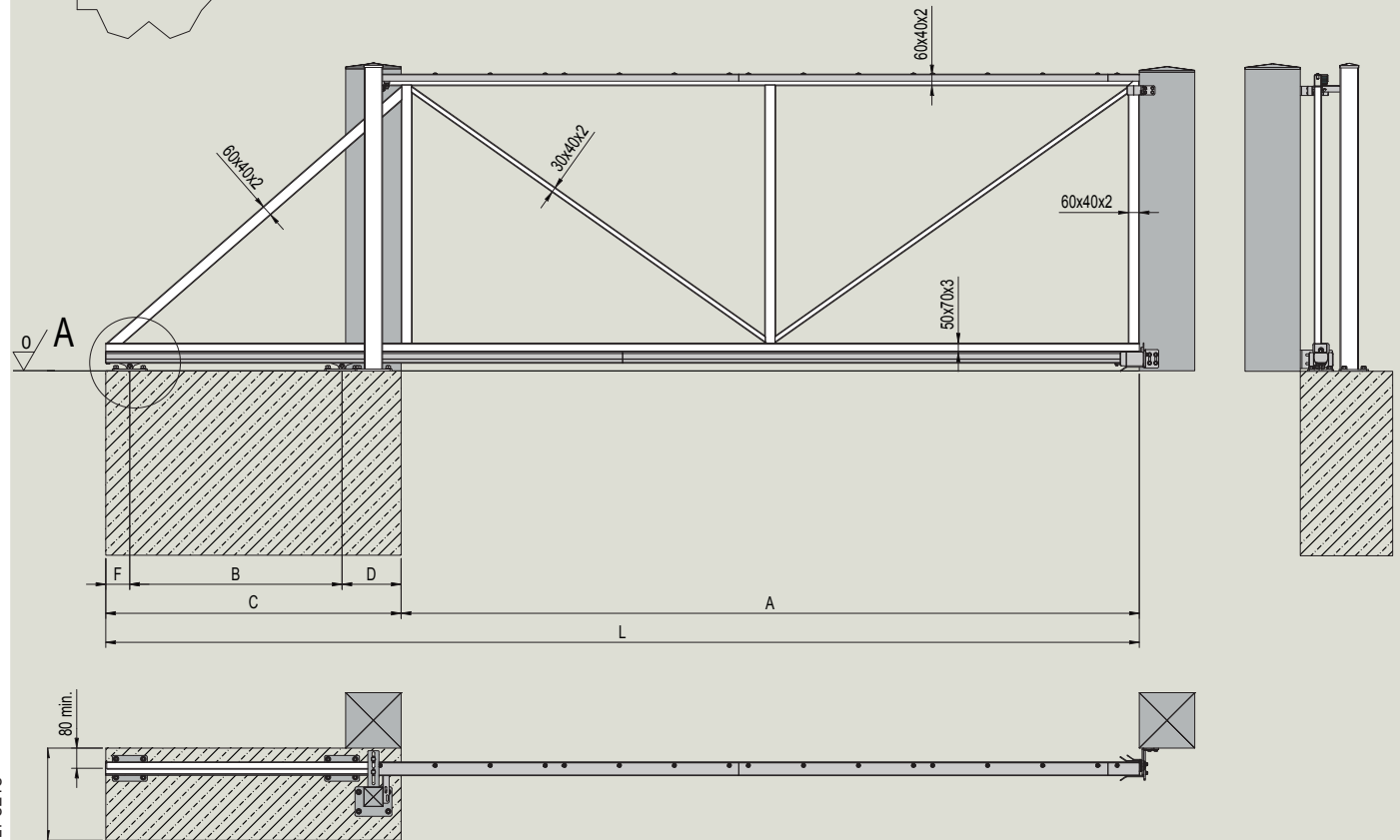
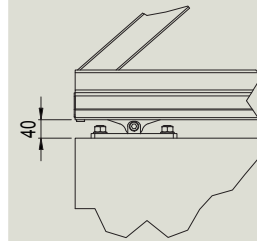

(*) ONLY SETS

FRAME NOT INCLUDED

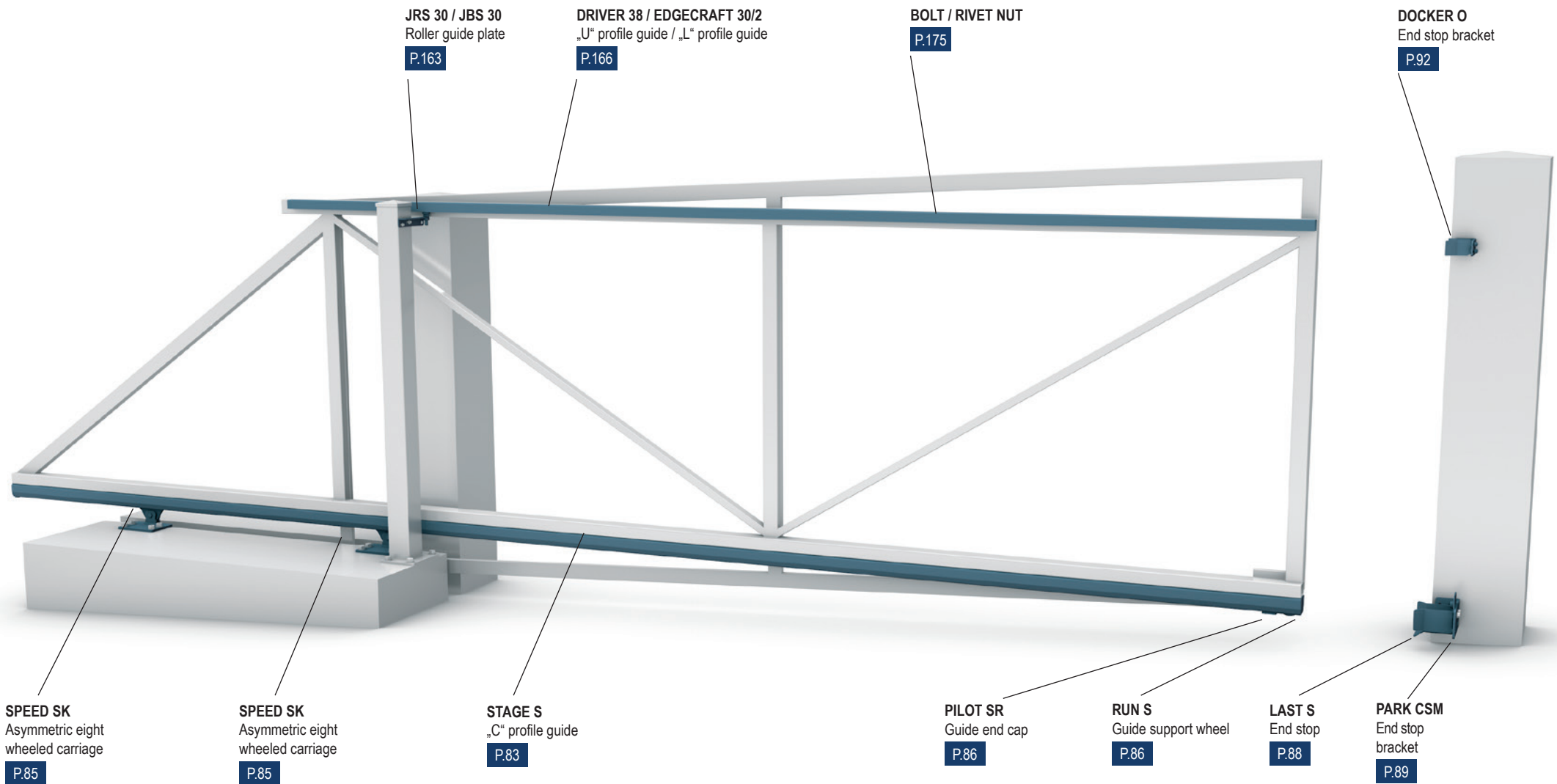





















CANTILEVER SK 4.5

CANTILEVER HARDWARE
 FOR INCLINED DRIVEWAY

CANTILEVER SK	mm; kg	mm; kg	mm; kg	mm; kg	mm; kg	mm; kg	mm; kg	mm; kg
A	3000	3200	3400	3600	3800	4000	4200	4500
max. weight gate	325 kg	325 kg	325 kg	350 kg	375 kg	400 kg	425 kg	450 kg
B	900	960	1020	1080	1140	1200	1260	1350
C	1440	1500	1560	1620	1680	1740	1800	1890
D	270	270	270	270	270	270	270	270

$$B = 0,3 \times A$$

$$L = A + B + (2 \times D) + E$$

-  SUITABLE FOR INCLINED DRIVEWAY INSTALLATION
-  EASY ASSEMBLY
-  FAST NO WELDING REQUIRED
-  15 BOLTS 15 RIVET NUTS INCLUDED (*)
-  «C» TRACK SERIAL NO. 100% COMPATIBILITY CARRIAGE TESTED
-  GERMAN STEEL
-  270 g/m² HOT DIPPED GALVANIZED
-  ARROW STRAIGHT «C» TRACK
-  SLOTTED HOLE PUNCHED EVERY 400mm IN TRACK
-  GALVANIZED INTERNAL EDGES
-  ASYMMETRIC EIGHT WHEELED CARRIAGE
-  C 2 HIGH QUALITY BEARINGS
-  CARRIAGES CENTER HOLES MILLED NOT LASER CUT
-  MULTI RIVETED SECTIONS
-  JAPANESE ROBOTICS FANUC
-  UNIVERSITY OF TECHNOLOGY – BRNO
-  - 37°C TESTED & PROVEN
-  + 50°C TESTED & PROVEN
-  MADE IN CZECH REPUBLIC
-  NO WELDING REQUIRED

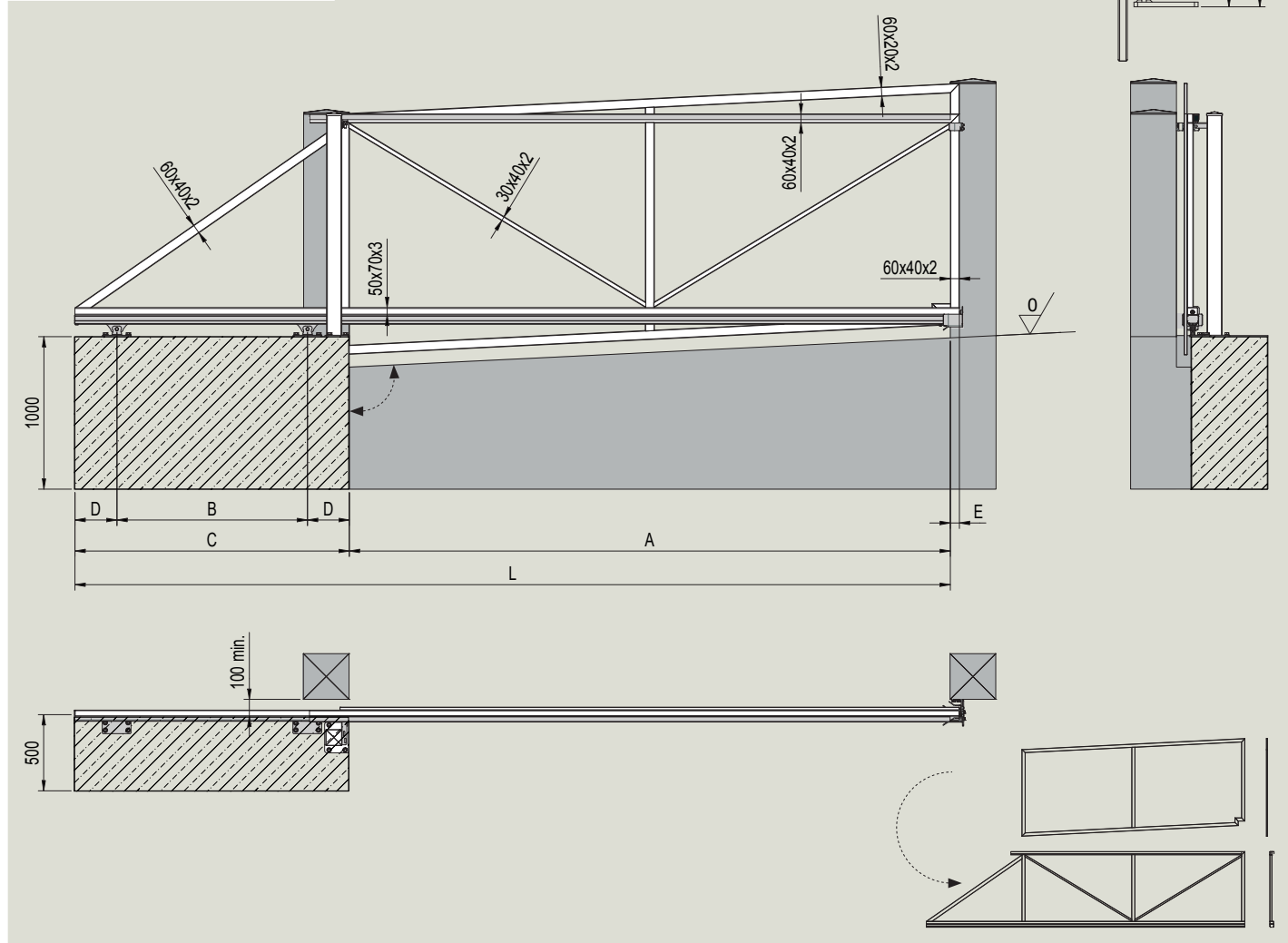



W Wuppermann

GERMAN STEEL

270
g/m²

HOT
DIPPED
GALVANIZED

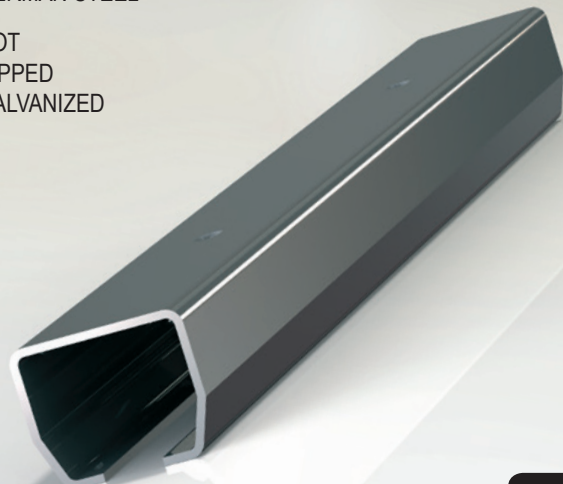

SPECIAL
THICKNESS

3,50
mm

24
months

24 MONTHS
TESTED
& PROVEN



- 37°C
TESTED
& PROVEN



+ 50°C
TESTED
& PROVEN



MADE IN THE
CZECH
REPUBLIC



SLOTTED HOLE
PUNCHED EVERY
400mm IN TRACK



15 BOLTS
15 RIVET NUTS
INCLUDED (*)



SERIAL NUMBER
CARRIAGE
TESTED & PROVEN

7105523



EASY
ASSEMBLY



FAST
NO WELDING REQUIRED



T BRNO
UNIVERSITY
OF TECHNOLOGY

7105523



ARROW
STRAIGHT
«C» TRACK



EIGHTEEN ROLL FORMERS
THE MOST IN THE INDUSTRY
REMOVE THE INSET «MEMORY» OF STEEL

18

AVAILABLE
CUSTOMISED LENGTHS
UNDER SPECIAL TERMS



SLOW ROLLING
NO HEAT DURING THE PRODUCTION
KEEPING THE MATERIAL WHERE IT IS ROLLED



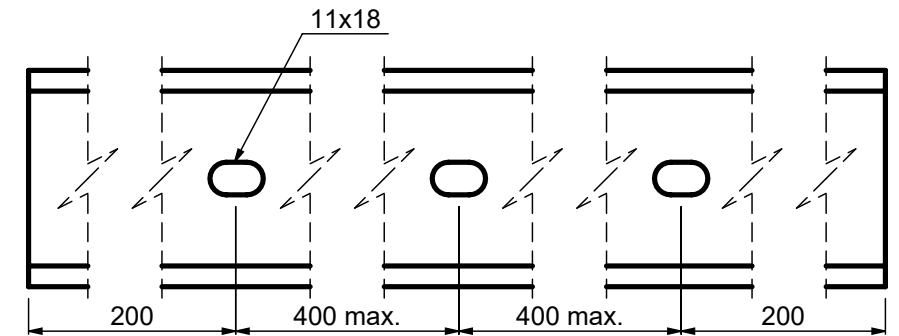
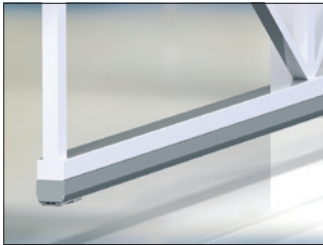
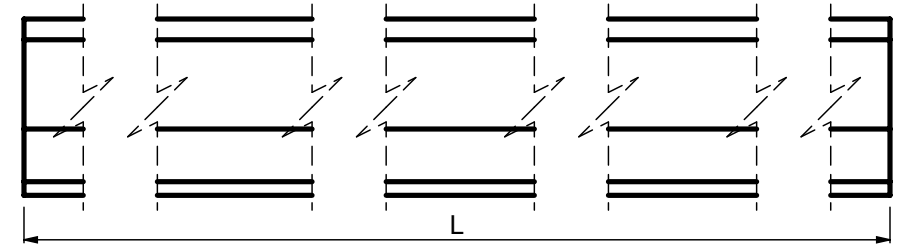
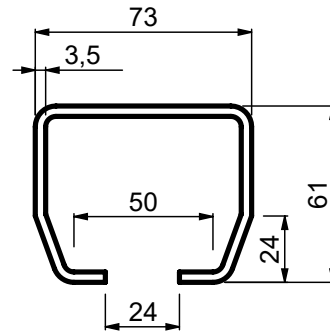
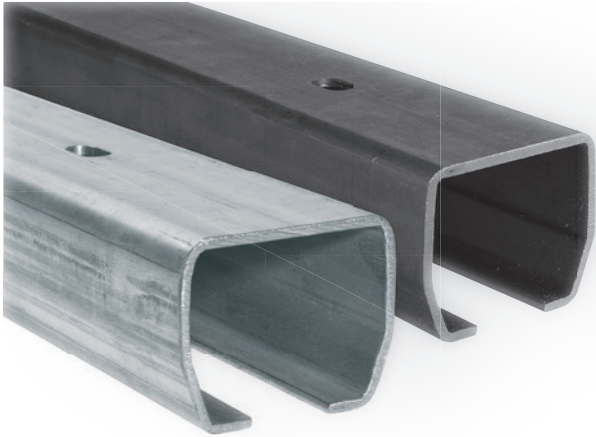





- (GB) „C“ PROFIL GUIDE FOR CANTILEVER GATE
- (D) „C“ PROFIL FÜR FREITRAGENDE SCHIEBETÖRE
- (F) GUIDE À PROFIL EN « C » POUR PORTAIL AUTOPORTANT
- (E) GUÍA CON PERFIL “C” PARA PUERTA VOLADIZA
- (P) GUIA DE PERFIL “C” PARA PORTÃO CANTILEVER
- (I) GUIDA CON PROFILO A “C” PER CANCELLO AUTOPORTANTE
- (DK) “C” PROFILVANGE TIL FRITBÆRENDE PORT
- (NL) “C” PROFIEL GELEIDER VOOR VRIJDRAGENDE SCHUIFPOORT
- (N) “C”-PROFILSKINNE FOR FRITTBÆRENDE PORTX
- (S) “C” GEJDPROFIL FÖR FRIBÄRANDE GRIND
- (FIN) “C” -PROFILLIÖHJAIN ULÖKEKANNETEISEEN PORTTIIN
- (PL) SZYNA DO BRAM SAMONOŚNYCH
- (SK) NOSNÝ „C“ PROFIL PRE POSUVNÚ SAMONOSNÚ BRÁNU
- (EE) “C” -PROFILLI JUHIK KONSOLVÄRAVA JAOKS
- (LT) „C“ FORMOS PROFILIUOTAS KREIPTUVAS GEMBINIAMS VARTAMS
- (LV) “C” VEIDA PROFILS KONSOLVEIDA VĀRTIEM

- (CZ) ŠÍNA „C“ PROFIL PRO POSUVNOU SAMONOSNOU BRÁNU
- (RO) GHIDAJ CU PROFIL „C“ PENTRU POARTA AUTOPORTANTĂ ÎN CONSOLĂ
- (HR) VODILICA „C“ PROFILA ZA KLIZNA DVORIŠNA VRATA
- (RU) НАПРАВЛЯЮЩИЙ РЕЛЬС / ПРОФИЛЬ «С» ДЛЯ ОТКАТНЫХ САМОНЕСУЩИХ ВОРОТ
- (SLO) “C” VODILO ZA SAMONOSNA DRNSNA VRATA
- (TR) KONSOL BAHÇE KAPISI İÇİN “C” PROFİL KIZAĞI
- (AR) للبوابة المدعومة “C” دعامة دليلية جانبية
- (CHN) 悬臂门“C”型导轨
- (MAL) PANDU PROFIL “C” UNTUK PINTU PAGAR JULUR
- (H) C-VEZETŐSÍN TOLÓKAPUHOZ
- (IL) קורה בפופיל “C” לשיעור קונסול
- (BG) “C”-ОБРАЗНА РЕЛІСА ЗА КОНЗОЛНА ВРАТА
- (KO) 캔틸레버 게이트용 “C”자형 프로필 가이드
- (SRB) VODICA „C“ PROFILA ZA SAMONOSIVU KAPIJU

Art.	CARRIAGE	GUIDE	L/1pc	1pc			CODE
					pcs	kg	
STAGE SB 6	SPEED S/SE/SK/LOWCUT	UNGALVANIZED	6000	33	24	792	1700002
STAGE SB 5,6	SPEED S/SE/SK/LOWCUT	UNGALVANIZED	5600	30,8	24	739,2	1700176
STAGE SB 3	SPEED S/SE/SK/LOWCUT	UNGALVANIZED	3000	16,5	24	396	1700167
STAGE SB 2,8	SPEED S/SE/SK/LOWCUT	UNGALVANIZED	2800	15,4	24	369,6	1720006
STAGE SB 1	SPEED S/SE/SK/LOWCUT	UNGALVANIZED	1000	5,5	24	132	1720008
STAGE SZ 6	SPEED S/SE/SK/LOWCUT	GALVANIZED	6000	33	24	792	1700003
STAGE SZ 5,6	SPEED S/SE/SK/LOWCUT	GALVANIZED	5600	30,8	24	739,2	1700177
STAGE SZ 3	SPEED S/SE/SK/LOWCUT	GALVANIZED	3000	16,5	24	396	1700168
STAGE SZ 2,8	SPEED S/SE/SK/LOWCUT	GALVANIZED	2800	15,4	24	369,6	1720016
STAGE SZ 1	SPEED S/SE/SK/LOWCUT	GALVANIZED	1000	5,5	24	132	1720018



-  C2 HIGH QUALITY BEARINGS
-  CARRIAGES CENTER HOLES MILLED NOT LASER CUT
-  MULTI RIVETED SECTIONS
- mono block** MONO BLOCK EIGHT WHEELED CARRIAGE
-  NO WELDED PARTS

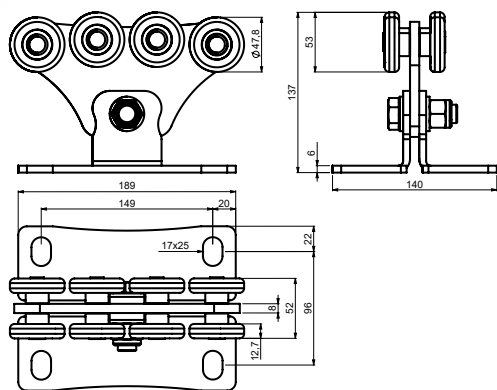



- (GB) ASYMMETRIC EIGHT WHEELED CARRIAGE FOR CANTILEVER GATE
- (D) ROLLAPPARAT MIT ACHT ROLLEN FÜR FREITRAGENDE SCHIEBETORE
- (F) CHARIOT À HUIT ROUES POUR PORTAIL AUTOPORTANT
- (E) CARRIL DE OCHO RUEDAS PARA PUERTA VOLADIZA
- (P) CORREDIÇA DE OITO ROLDANAS PARA PORTÃO CANTILEVER
- (I) CARRELLO A OTTO RUOTE PER CANCELLO AUTOPORTANTE
- (DK) OTTE TRANSPORTHJUL TIL FRITTBÆRENDE PORT
- (NL) ACHTVOUDIG WIELENBLOK VOOR VRIJDRAGENDE SCHUIFPOORT
- (N) ATTEHJULS DRIVSKINNE TIL FRITTBÆRENDE PORT
- (S) ÅTTAHJULIG VAGN FÖR FRIBÄRANDE GRIND
- (FIN) KAHDEKSAN PYÖRÄN ALUSTA ULOKEKANNETIESEEN PORTTIIN
- (PL) WÓZEK 8-ROLKOWY DO BRAM SAMONOŚNYCH
- (SK) VOZÍK OSEM KOLIEČKOVÝ PRE POSUVNÚ SAMONOSNÚ BRÁNU
- (EE) KAHEKSARATTALINE SUPORT KONSOLVÄRAVA JAOKS
- (LT) VEŽIMĖLIS GEMBINIAMS VARTAMS SU AŠTUONIAIS RATUKAIS
- (LV) ASTOŅU RUĻĻU BLOKS KONSOLVEIDA VĀRTIEM

- (CZ) VOZÍK OSMIKOLOVÝ PRO POSUVNOU SAMONOSNOU BRÁNU
- (RO) CĂRUCIOR PE OPT ROȚI PENTRU POARTA AUTOPORTANTĂ ÎN CONSOLĂ
- (HR) NOSAČ S OSAM KOTAČA ZA KLIZNA DVORIŠNA VRATA
- (RUS) ВОСЬМИКОЛЕСНАЯ РОЛИКОВАЯ ТЕЛЕЖКА ДЛЯ ОТКАТНЫХ САМОНЕСУЩИХ ВОРОТ
- (SLO) VOZIČEK Z OSMIMI KOLESI ZA SAMONOSNA DRSNA VRATA
- (TR) KONSOL BAHÇE KAPISI İÇİN SEKİZ TEKERLEKLİ TAŞIYICI
- (AR) عربة مزودة بشعبي عجلات للوابت المدعنة
- (CHN) 悬臂门八轮滑架
- (MAL) PENYORONG LAPAN RODA UNTUK PINTU PAGAR JULUR
- (H) NYOLCGÖRGÖS FUTÓKOCSI TOLÓKAPUHOZ
- (IL) קרונית שמנונה גלגלים לשער קונדולי
- (BG) КОЛИЧКА С ОСЕМ РОЛКИ ЗА КОНЗОЛНА ВРАТА
- (KO) 8개 휠이 있는 캔틸레버 게이트용 이송대
- (SRB) NOSAČ SA OSAM TOČKIČA ZA SAMONOSIVU KAPIJU

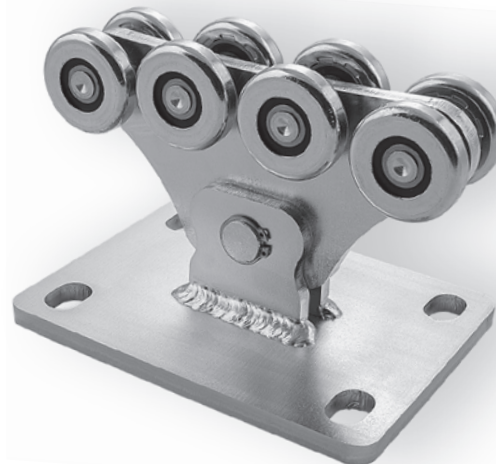
Art.	A	GUIDE	1pc			CODE
			kg	pcs	kg	
SPEED SE	4000	STAGE SB/SZ	3,5	2	7	1700174



-  C2 HIGH QUALITY BEARINGS
-  CARRIAGES CENTER HOLES MILLED NOT LASER CUT
-  MULTI RIVETED SECTIONS
- mono block** MONO BLOCK EIGHT WHEELED CARRIAGE

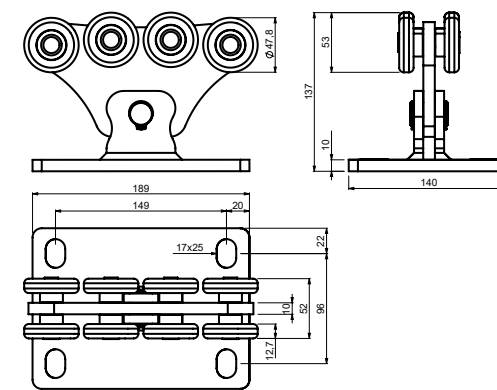





- (GB) EIGHT WHEELED CARRIAGE FOR CANTILEVER GATE
- (D) ROLLAPPARAT MIT ACHT ROLLEN FÜR FREITRAGENDE SCHIEBETORE
- (F) CHARIOT À HUIT ROUES POUR PORTAIL AUTOPORTANT
- (E) CARRIL DE OCHO RUEDAS PARA PUERTA VOLADIZA
- (P) CORREDIÇA DE OITO ROLDANAS PARA PORTÃO CANTILEVER
- (I) CARRELLO A OTTO RUOTE PER CANCELLO AUTOPORTANTE
- (DK) OTTE TRANSPORTHJUL TIL FRITTBÆRENDE PORT
- (NL) ACHTVOUDIG WIELENBLOK VOOR VRIJDRAGENDE SCHUIFPOORT
- (N) ATTEHJULS DRIVSKINNE TIL FRITTBÆRENDE PORT
- (S) ÅTTAHJULIG VAGN FÖR FRIBÄRANDE GRIND
- (FIN) KAHDEKSAN PYÖRÄN ALUSTA ULOKEKANNETIESEEN PORTTIIN
- (PL) WÓZEK 8-ROLKOWY DO BRAM SAMONOŚNYCH
- (SK) VOZÍK OSEM KOLIEČKOVÝ PRE POSUVNÚ SAMONOSNÚ BRÁNU
- (EE) KAHEKSARATTALINE SUPORT KONSOLVÄRAVA JAOKS
- (LT) VEŽIMĖLIS GEMBINIAMS VARTAMS SU AŠTUONIAIS RATUKAIS
- (LV) ASTOŅU RUĻĻU BLOKS KONSOLVEIDA VĀRTIEM

- (CZ) VOZÍK OSMIKOLOVÝ PRO POSUVNOU SAMONOSNOU BRÁNU
- (RO) CĂRUCIOR PE OPT ROȚI PENTRU POARTA AUTOPORTANTĂ ÎN CONSOLĂ
- (HR) NOSAČ S OSAM KOTAČA ZA KLIZNA DVORIŠNA VRATA
- (RUS) ВОСЬМИКОЛЕСНАЯ РОЛИКОВАЯ ТЕЛЕЖКА ДЛЯ ОТКАТНЫХ САМОНЕСУЩИХ ВОРОТ
- (SLO) VOZIČEK Z OSMIMI KOLESI ZA SAMONOSNA DRSNA VRATA
- (TR) KONSOL BAHÇE KAPISI İÇİN SEKİZ TEKERLEKLİ TAŞIYICI
- (AR) عربة مزودة بشعبي عجلات للوابت المدعنة
- (CHN) 悬臂门八轮滑架
- (MAL) PENYORONG LAPAN RODA UNTUK PINTU PAGAR JULUR
- (H) NYOLCGÖRGÖS FUTÓKOCSI TOLÓKAPUHOZ
- (IL) קרונית שמנונה גלגלים לשער קונדולי
- (BG) КОЛИЧКА С ОСЕМ РОЛКИ ЗА КОНЗОЛНА ВРАТА
- (KO) 8개 휠이 있는 캔틸레버 게이트용 이송대
- (SRB) NOSAČ SA OSAM TOČKIČA ZA SAMONOSIVU KAPIJU

Art.	A	GUIDE	1pc			CODE
			kg	pcs	kg	
SPEED S	4500	STAGE SB/SZ	4,7	2	9,4	1700001



-  SUITABLE FOR INCLINED DRIVEWAY INSTALLATION
-  ASYMMETRIC EIGHT WHEELED CARRIAGE
-  C 2 HIGH QUALITY BEARINGS
- mono block** MONO BLOCK EIGHT WHEELED CARRIAGE
-  CARRIAGES CENTER HOLES MILLED NOT LASER CUT
-  MULTI RIVETED SECTIONS

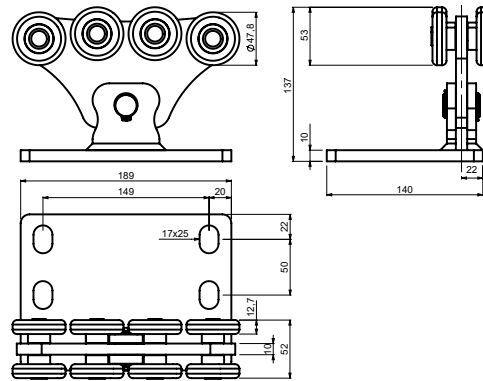

- (GB) EIGHT WHEELED CARRIAGE FOR CANTILEVER GATE
- (D) ROLLAPPARAT MIT ACHT ROLLEN FÜR FREITRAGENDE SCHIEBETÖRE
- (F) CHARIOT À HUIT ROUES POUR PORTAIL AUTOPORTANT
- (E) CARRIL DE OCHO RUEDAS PARA PUERTA VOLADIZA
- (P) CORREDIÇA DE OITO ROLDANAS PARA PORTÃO CANTILEVER
- (I) CARRELLO A OTTO RUOTE PER CANCELLO AUTOPORTANTE
- (DK) OTTE TRANSPORTHJUL TIL FRITTBÆRENDE PORT
- (NL) ACHTVOUDIG WIELENBLOK VOOR VRIJDRAGENDE SCHUIFPOORT
- (N) ATTEHJULS DRIVSKINNE TIL FRITTBÆRENDE PORT
- (S) ATTAHJULIG VAGN FÖR FRIBÄRANDE GRIND
- (FIN) KAHDEKSAN PYÖRÄN ALUSTA ULÖKEKANNETTEISEEN PORTTIIN
- (PL) WÓZEK 8-ROLKOWY DO BRAM SAMONOŚNYCH
- (SK) VOZÍK OSEM KOLIEČKOVÝ PRE POSUVNÚ SAMONOSNÚ BRÁNU
- (EE) KAHEKSARATTALINE SUPORT KONSOLVÄRAVA JAOKS
- (LT) VEŽIMĖLIS GEMBINIAMS VARTAMS SU AŠTUONIAIS RATUKAIS
- (LV) ASTOŅU RUĻĻU BLOKS KONSOLVEIDA VĀRTIEM

- (CZ) VOZÍK OSMIKOLOVÝ PRO POSUVNOU SAMONOSNOU BRÁNU
- (RO) CĂRUȚIOR PE OPT ROTI PENTRU POARTA AUTOPORTANTĂ ÎN CONSOLĂ
- (HR) NOSAČ S OSAM KOTAČA ZA KLIZNA DVORIŠNA VRATA
- (RUS) ВОСЬМИКОЛЕСНАЯ РОЛИКОВАЯ ТЕЛЕЖКА ДЛЯ ОТКАТНЫХ САМОНЕСУЩИХ ВОРОТ
- (SLO) VOZIČEK Z OSMIMI KOLESI ZA SAMONOSNA DRSNA VRATA
- (TR) KONSOL BAHÇE KAPISI İÇİN SEKİZ TEKERLEKLİ TAŞIYICI
- (AR) عربة مزودة بشعبي عدلات اللولبات المدعمة
- (CHN) 悬臂门八轮滑架
- (MAL) PENYORONG LAPAN RODA UNTUK PINTU PAGAR JULUR
- (H) NYOLCGÖRGÖS FUTÓKOCSI TOLÓKAPUHOZ
- (IL) קרונית שמונה גלגלים לשער קנולוי
- (BG) КОЛИЧКА С ОСЕМ РОЛКИ ЗА КОНЗОЛНА ВРАТА
- (KO) 8개 휠이 있는 캔틸레버 게이트용 이송대
- (SRB) NOSAČ SA OSAM TOČKIČA ZA SAMONOSIVU KAPIJU

Art.	A	GUIDE	1pc			CODE
	max. mm			kg	pcs	
SPEED SK	4500	STAGE SB/SZ	4,7	2	9,4	1700189

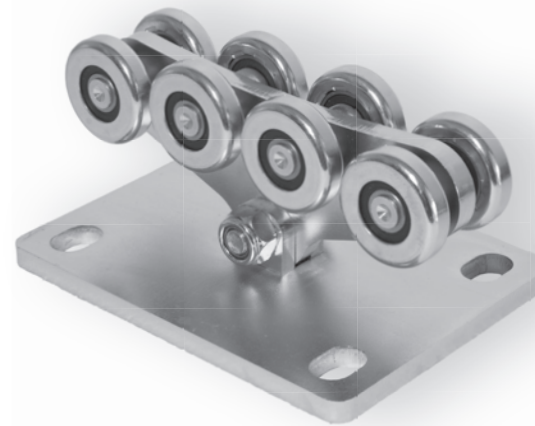

-  C 2 HIGH QUALITY BEARINGS
-  CARRIAGES CENTER HOLES MILLED NOT LASER CUT
-  MULTI RIVETED SECTIONS
- mono block** MONO BLOCK EIGHT WHEELED CARRIAGE

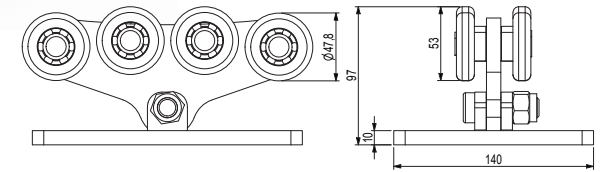

NEW

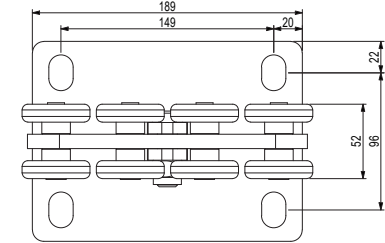

- (GB) EIGHT WHEELED CARRIAGE FOR CANTILEVER GATE
- (D) ROLLAPPARAT MIT ACHT ROLLEN FÜR FREITRAGENDE SCHIEBETÖRE
- (F) CHARIOT À HUIT ROUES POUR PORTAIL AUTOPORTANT
- (E) CARRIL DE OCHO RUEDAS PARA PUERTA VOLADIZA
- (P) CORREDIÇA DE OITO ROLDANAS PARA PORTÃO CANTILEVER
- (I) CARRELLO A OTTO RUOTE PER CANCELLO AUTOPORTANTE
- (DK) OTTE TRANSPORTHJUL TIL FRITTBÆRENDE PORT
- (NL) ACHTVOUDIG WIELENBLOK VOOR VRIJDRAGENDE SCHUIFPOORT
- (N) ATTEHJULS DRIVSKINNE TIL FRITTBÆRENDE PORT
- (S) ATTAHJULIG VAGN FÖR FRIBÄRANDE GRIND
- (FIN) KAHDEKSAN PYÖRÄN ALUSTA ULÖKEKANNETTEISEEN PORTTIIN
- (PL) WÓZEK 8-ROLKOWY DO BRAM SAMONOŚNYCH
- (SK) VOZÍK OSEM KOLIEČKOVÝ PRE POSUVNÚ SAMONOSNÚ BRÁNU
- (EE) KAHEKSARATTALINE SUPORT KONSOLVÄRAVA JAOKS
- (LT) VEŽIMĖLIS GEMBINIAMS VARTAMS SU AŠTUONIAIS RATUKAIS
- (LV) ASTOŅU RUĻĻU BLOKS KONSOLVEIDA VĀRTIEM

- (CZ) VOZÍK OSMIKOLOVÝ PRO POSUVNOU SAMONOSNOU BRÁNU
- (RO) CĂRUȚIOR PE OPT ROTI PENTRU POARTA AUTOPORTANTĂ ÎN CONSOLĂ
- (HR) NOSAČ S OSAM KOTAČA ZA KLIZNA DVORIŠNA VRATA
- (RUS) ВОСЬМИКОЛЕСНАЯ РОЛИКОВАЯ ТЕЛЕЖКА ДЛЯ ОТКАТНЫХ САМОНЕСУЩИХ ВОРОТ
- (SLO) VOZIČEK Z OSMIMI KOLESI ZA SAMONOSNA DRSNA VRATA
- (TR) KONSOL BAHÇE KAPISI İÇİN SEKİZ TEKERLEKLİ TAŞIYICI
- (AR) عربة مزودة بشعبي عدلات اللولبات المدعمة
- (CHN) 悬臂门八轮滑架
- (MAL) PENYORONG LAPAN RODA UNTUK PINTU PAGAR JULUR
- (H) NYOLCGÖRGÖS FUTÓKOCSI TOLÓKAPUHOZ
- (IL) קרונית שמונה גלגלים לשער קנולוי
- (BG) КОЛИЧКА С ОСЕМ РОЛКИ ЗА КОНЗОЛНА ВРАТА
- (KO) 8개 휠이 있는 캔틸레버 게이트용 이송대
- (SRB) NOSAČ SA OSAM TOČKIČA ZA SAMONOSIVU KAPIJU

Art.	A	GUIDE	1pc			CODE
	max. mm			kg	pcs	
SPEED S - LOWCUT	4000	STAGE SB/SZ	4,1	2	8,2	1700395

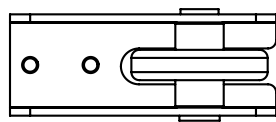
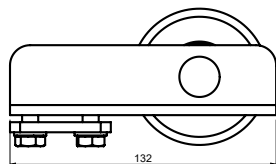
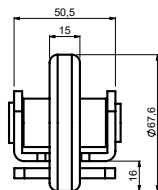

- (GB) GUIDE SUPPORT WHEEL FOR CANTILEVER GATE
 (D) STÜTZRAD FÜR FREITRAGENDE SCHIEBETORE
 (F) ROUE DE SUPPORT DE GUIDE POUR PORTAIL AUTOPORTANT
 (E) RUEDA CON SOPORTE DE GUÍA PARA PUERTA VOLADIZA
 (P) ROLDANA DE SUPORTE GUIA PARA PORTÃO CANTILEVER
 (I) RUOTA DI SOSTEGNO DELLA GUIDA PER CANCELLO AUTOPORTANTE
 (DK) VANGESTØTTEHJUL TIL FRITBÆRENDE PORT
 (NL) DRAAGWIEL VOOR GELEIDING VRIJDRAGENDE SCHUIFPOORT
 (N) STYRESKINNE FOR STØTTEHJUL TIL FRITBÆRENDE PORT
 (S) STÖDHJUL FÖR FRIBÄRANDE GRIND
 (FIN) OHJAIMEN TUKIPYÖRÄ ULKEKANNETTEISEEN PORTTIIN
 (PL) ROLKA NAJAZDOWA DO BRAM SAMONOŚNYCH
 (SK) NÁBEH S KLDKOU PRE POSUVNÚ SAMONOSNÚ BRÁNU
 (EE) JUHI TUGIRATAS KONSOOLVÄRAVA JAOKS
 (LT) KREIPTUVO ATRAMOS RATUKAS GEMBINIAMS VARTAMS
 (LV) VADOTNES BALSTA RULLĪTIS KONSOLVEIDA VĀRTIEM

- (CZ) NÁBĚH S KLDKOU PRO POSUVNOU SAMONOSNOU BRÁNU
 (RO) ROATĂ DE SUSȚINERE GHIDAJ PENTRU POARTA AUTOPORTANTĂ ÎN CONSOLĂ
 (HR) NOSIVI KOTAČ VODILICE ZA KLIZNA DVORIŠNA VRATA
 (RUS) КОНЦЕВОЙ РОЛИК ДЛЯ ОТКАТНЫХ САМОНЕСУЩИХ ВОРОТ
 (SLO) PODPORNO KOLO VODILA ZA SAMONOSNA DRŠNA VRATA
 (TR) KONSOL BAHÇE KAPISI İÇİN KIZAK DESTEK TEKERLEĞİ
 (AR) عجلة دعمية للبوابة المعلقة
 (CHN) 悬臂门导轨支轮
 (MAL) RODA SOKONGAN PANDU UNTUK PINTU PAGAR JULUR
 (H) VEZETŐ, MEGTÁMASZTÓ GÖRGŐ TOLÓKAPUHOZ
 (IL) גלגל תומך לשיער קונזולי
 (BG) РОЛКА ЗА РЕЛСА ЗА КОНЗОЛНА ВРАТА
 (KO) 캔틸레버 게이트용 가이드 지지 휠
 (SRB) NOSEĆI TOČKIĆ VODICE ZA SAMONOSIVU KAPIJU

Art.	GUIDE	1pc			CODE
		kg	pcs	kg	
RUN S	STAGE SB/SZ	0,97	10	9,7	1700004

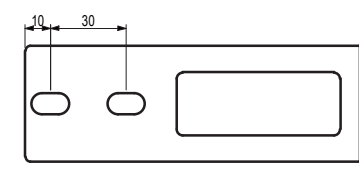
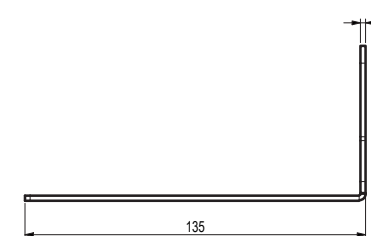
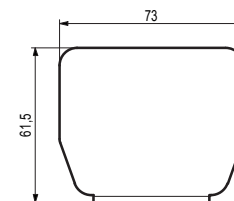
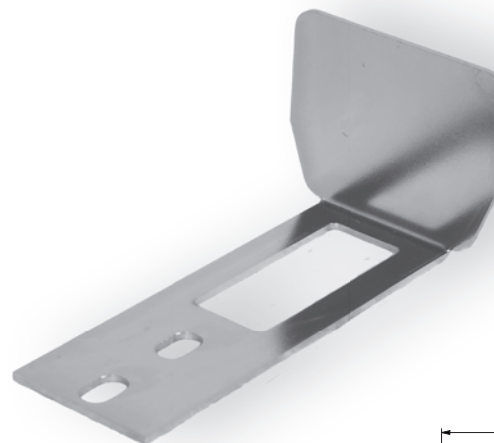

- (GB) END CAP WITH BOTTOM PLATE FOR CANTILEVER S GUIDE WHEEL
 (D) ENDKAPPE MIT BODENPLATTE FÜR CANTILEVER S-FÜHRUNGSRAD
 (F) CACHE D'EXTRÉMITÉ AVEC PLATINE BASSE POUR ROULETTE DE GUIDAGE PORTE-À-FAUX S
 (E) TAPA FINAL CON PLACA INFERIOR PARA RUEDA GUÍA EN VOLADIZO S
 (P) TAMPA DE EXTREMIDADE COM PLACA INFERIOR PARA RODA GUIA CANTILEVER S
 (I) CAPPUCCIOTERMINALE CON PIASTRA INFERIORE PER RUOTA DI GUIDA CANTILEVER S
 (DK) ENDEKAPPE MED BUNNPLADE TIL S-STYREHJUL TIL UDKRAGNING
 (NL) AFDEKKAP MET BODEMPLAAT VOOR LEIWIJEL VAN CANTILEVER S
 (N) ENDEKAPPE MED BUNNPLATE FOR S-FORMET STYREHJUL TIL UTLIGGER
 (S) ÄNDKAPA MED BOTTENPLATTA FÖR KONSOL S-STYRHJUL
 (FIN) PÄÄTYKAPPALE JA POHJALEVY ULKEKALKIN S-OHJASPYÖRÄÄ VARTEN
 (PL) ZAŚLEPKA Z DOLNĄ PŁYTKĄ DO KOLA PROWADZĄCEGO SYSTEMÓW WSPORNIKOWYCH TYPU S
 (SK) SPODNÁ KONCOVÁ PÁČICA VODIACEHO KOLIESKA SAMONOSNEJ POSUVNEJ BRÁNY S
 (EE) ALUSPLAADIGA OTSAKORK TIBVÄRAVA S JUHTRATTALE
 (LT) GALINIS DANGTELIS SU APATINE PLOKŠTELE, SKIRTAS KONSOLINIŲ VARTŲ S KREIPIAMAJAM RATUKUI
 (LV) GALA UZGALIS AR APAKŠĒJO PLĀKŠNI ZOBSTIENĀ S VIRZOŠAJAM RITENIM

- (CZ) ZÁSLEPKA POR ŠINU „C“ PROFIL, PRO RUN S
 (RO) CAPAC DE ÎNCHIDERE CU PLACĂ INFERIOARĂ PENTRU ROATĂ DE GHIDARE CANTILEVER S
 (HR) ZAVRŠNI ČEP S DONJOM PLOČOM ZA KOTAČ VODILICE CANTILEVER S
 (RUS) ТОРЦЕВАЯ ПЛАНКА С НИЖНЕЙ ПЛАСТИНОЙ ДЛЯ НАПРАВЛЯЮЩЕГО КОЛЕСА САМОНЕСУЩИХ ОТКАТНЫХ ВОРОТ S
 (SLO) POKROV S SPODNJO PLOŠČO ZA VODILNO KOLESCE ZA SISTEM CANTILEVER S
 (TR) KONSOL KIRIŞ S KILAVUZ TEKERLEĞİ İÇİN ALT PLAKALI UÇ KAPAĞI
 (AR) غطاء طرفي مع لوحة سفلية لعجلة التوجيه حرف S للبوابة الكابولية
 (CHN) 用于悬臂梁S导向轮的带底板端盖
 (MAL) TUKUP Hujung dengan Plat Bawah untuk Roda Pandu Julur S
 (H) VÉGZÁRÓ TALPLEMEZZEL S ÚSZÓKAPU VEZETŐKERÉKHEZ
 (IL) עבור שיער קונזולי S כיוסי קצה עם פלטה תחתונה לגלגל מוביל מסוג
 (BG) НАКРАЙНИК С ДОЛНА ПЛОЧА ЗА ВОДЕЩО КОЛЕЛО ЗА КОНЗОЛНИ ВРАТИ S
 (KO) 캔틸레버 S 가이드 휠용 하부 플레이트 일체형 엔드캡
 (SRB) ZAVRŠNI ČEP S DONJOM PLOČOM ZA KOTAČ VODILICE CANTILEVER S

Art.	GUIDE	1pc			CODE
		kg	pcs	kg	
PILOT SR	STAGE SB/SZ	0,14	10	1,4	1700404

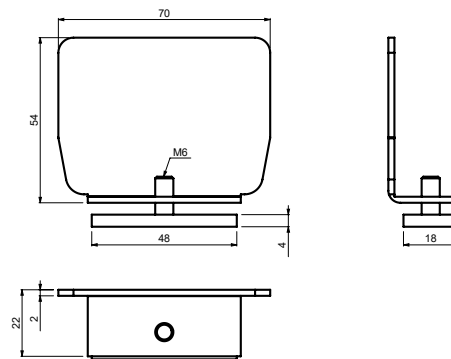

- (GB) GUIDE END CAP WITH SCREW, INDEPENDENT
 (D) ABSCHLUSSKAPPE FÜR „C“ PROFIL AUS STAHL MIT SCHRAUBE
 (F) CACHE D'EMBOUIT DE GUIDE AVEC VIS, INDÉPENDANT
 (E) TOPE FINAL DE GUÍA CON TUERCA, INDEPENDIENTE
 (P) TAMPA FINAL GUIA COM PARAFUSO, INDEPENDENTE
 (I) COPERTURA TERMINALE DELLA GUIDA CON VITE, INDIPENDENTE
 (DK) VANGEENDEHÆTTE MED SKRUE, UAFHÆNGIG
 (NL) GELEIDER EINDKAP MET SCHROEF, ONAFHANKELIJK
 (N) ENDEBESLAG FOR SKINNE MED SKRUE, UAFHENGIG
 (S) GEJLD SKYDDSKÅPA MED SKRUV, OBEROENDE
 (FIN) OHJAIMEN PÄÄN RUUVILLINEN KANSI, ERILLINEN
 (PL) ZAŚLEPKA KOŃCOWA SZYNY ZE ŚRUBĄ, NIEZALEŻNA
 (SK) ZÁSLEPKA PRE NOSNÝ „C“ PROFIL, NEZÁVISLÁ SO SKRUTKOU
 (EE) JUHIKU OTSAKORK KRUVIGA, ERALDI
 (LT) GALINIS KREIPTUVO DANGTELIS SU ŠRIEGIU, ATSKIRAS
 (LV) VADOTNES GALA VĀKS AR SKRŪVI, NEATKARĪGS

- (CZ) ZÁSLEPKA PRO ŠINU „C“ PROFIL, NEZÁVISLÁ SE ŠROUBEM
 (RO) OPRITOR CURSĂ ACOPERIRE GHIDAJ CU FILET, INDEPENDENT
 (HR) ČEP VODILICE S VIJKOM, NEOVISAN
 (RUS) ЗАГЛУШКА НАПРАВЛЯЮЩЕГО РЕЛЬСА «С», НЕЗАВИСИМАЯ, С ВИНТОМ
 (SLO) ZAKLJUČNI POKROV VODILA Z VIJAKOM, NEODVISEN
 (TR) VİDALI KIZAK UÇ LASTIĞI, BAĞIMSIZ
 (AR) غطاء طرفي دليلي مع برغي، مستقل
 (CHN) 导轨独立式螺钉紧固端盖
 (MAL) PENUTUP Hujung Pandu Dengan Skru, Bebas
 (H) VEZETŐSÍN LEZÁRÓ-ELEM CSAVARRAL, FÜGGETLEN
 (IL) מכסה קצה קורה קונדוליט עם בורג, עצמאי
 (BG) КРАЙНА КАПЧКА ЗА РЕЛСА С ВИНТ, САМОСТОЯТЕЛНА
 (KO) 나사가 있는 가이드 종단 캡, 독립식
 (SRB) ČEP VODICE SA ZAVRTNEM, NEZAVISAN

Art.	GUIDE	1pc			CODE
		kg	pcs	kg	
PILOT SN	STAGE SB/SZ	0,1	10	1	1700007

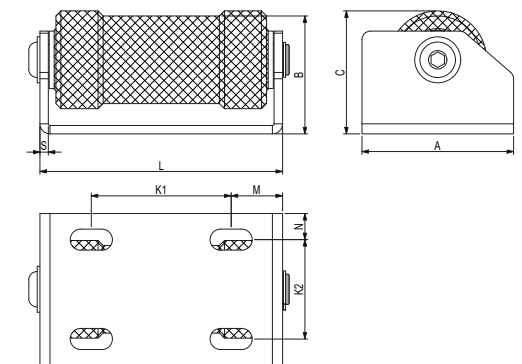
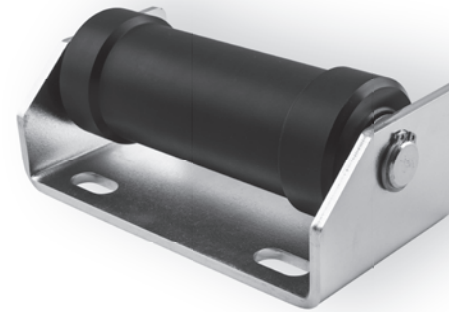

- (GB) SUPPORT ROLLER FOR CANTILEVER GATE
 (D) STÜTZROLLE FÜR AUSLEGERTOR
 (F) ROULEAU DE SUPPORT POUR PORTAIL COULISSANT AUTOPORTANT
 (E) RODILLO DE SOPORTE PARA PORTÓN EN VOLADIZO
 (P) ROLO DE SUPORTE PARA PORTÃO DE CANTILEVER
 (I) RULLO DI SOSTEGNO PER CANCELLO AUTOPORTANTE
 (DK) STØTTERULLE TIL FRITBÆRENDE PORT
 (NL) STEUNROL VOOR SCHUIFPOORT
 (N) STØTTERULLE FOR RULLEPORT
 (S) STÖDRULLE FÖR FRIBÄRANDE GRIND
 (FIN) TUKIRULLA ULOKEPORTTIIN
 (PL) RÓLKA DOLNA DO BRAMY SAMONOŚNEJ
 (SK) PODPORNÝ VALEC PRE SAMONOSNÉ BRÁNY
 (EE) TUGIRULLIK KONSOOLVÄRAVA JAOKS
 (LT) ATRAMINIS RITINĖLIS GEMBINIAMS VARTAMS
 (LV) BALSTA RULLĪTIS KONSOLVEIDA VĀRTIEM

- (CZ) KONZOLA S KLDKOU PRO PODPĚRU POSUVNÉ SAMONOSNÉ BRÁNY
 (RO) ROLĂ DE SUSȚINERE PENTRU POARTA ÎN CONSOLĂ
 (HR) POTPORNİ VALJAK ZA NOSİVA VRATA
 (RUS) ОПОРНЫЙ РОЛИК ДЛЯ САМОНЕСУЩИХ ВОРОТ
 (SLO) PODPORNİ VALJ ZA SAMONOSNA DRSNA VRATA
 (TR) MANİVELA KAPİ İÇİN DESTEK MAKARASI
 (AR) المسطوانة الداعمة لوابية الكابول
 (CHN) 悬臂门支承辊
 (MAL) PENGGELEK SOKONGAN UNTUK GET JULUR
 (H) TARTÓGÖRGŐ TOLÓKAPUHOZ
 (IL) גלגל תמיכה לשער קונדוליט
 (BG) ПОДДЪРЖАЩА РОЛКА ЗА КОНЗОЛНА ВРАТА
 (KO) 캔틸레버 게이트용 지지 롤러
 (SRB) NOSEĆI VALJAK ZA SAMONOSIVU KAPIJU

Art.	L	A	B	C	J	K1	K2	M	N	S	1pc			CODE	
											kg	pcs	kg		
													mm		
DRIVESHAFT 80	144	90	70	73	13x25	107	60	31	15	5	1,37	4	5,48	1700332	
DRIVESHAFT 100	169	90	70	73	13x25	107	60	31	15	5	1,56	4	6,24	1700333	



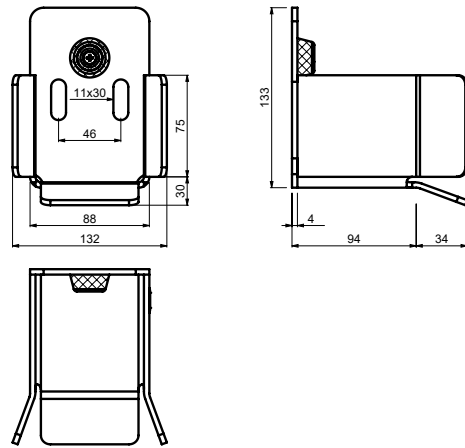
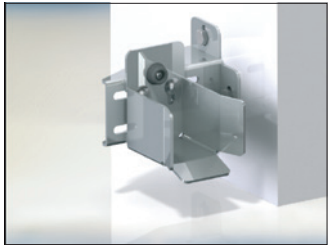

- (GB) END STOP FOR CANTILEVER GATE
- (D) EINLAUFSCHUH FÜR FREITRAGENDE SCHIEBETORE
- (F) BUTÉE POUR PORTAIL AUTOPORTANT
- (E) TOPE FINAL PARA PUERTA VOLADIZA
- (P) BATERIA PARA PORTÃO CANTILEVER
- (I) FERMO DI FINE CORSA PER CANCELLO AUTOPORTANTE
- (DK) ENDESTOP TIL FRITTBÆRENDE PORT
- (NL) EINDSTOP VOOR VRIJDRAGENDE SCHUIFPOOR
- (N) ENDESTOPPER FOR FRITTBÆRENDE PORT
- (S) ÄNDSTOPP FÖR FRIBÄRENDE GRIND
- (FIN) PÄÄTYPYSÄYTIN ULKOKANNETTEISEEN PORTTIIN
- (PL) ODBOJNIK DO BRAM SAMONOŚNYCH
- (SK) DOJAZDOVÁ KAPSA SPODNÁ PRE POSUVNÚ SAMONOSNÚ BRÁNU
- (EE) OTSALOPP KONSOLVÄRAVA JAOKS
- (LT) GALINIS RIBOKLIS GEMBINIAMS VARTAMS
- (LV) GALA AIZTURIS KONSOLVEIDA VĀRTIEM

- (CZ) DOJAZDOVÁ KAPSA SPODNÍ PRO POSUVNOU SAMONOSNOU BRÁNU
- (RO) OPRITOR CURSĂ PENTRU POARTA AUTOPORTANTĂ ÎN CONSOLĂ
- (HR) GRANIČNIK ZA KLIZNA DVORIŠNA VRATA
- (RUS) УЛАВЛИВАТЕЛЬ НИЖНИЙ ДЛЯ ОТКАТНЫХ САМОНЕСУЩИХ ВОРОТ
- (SLO) ZAUSTAVLJALNIK ZA SAMONOSNA DRŠNA VRATA
- (TR) KONSOL BAĖÇE KAPISI İÇİN UÇ TESPİT PARÇASI
- (AR) المدع الطرفي للبوابة المنعقدة
- (CHN) 悬臂门终点挡块
- (MAL) PENYENDAL Hujung Untuk Pintu Pagar Julur
- (H) ŰTKÖZŐ TOLÓKAPUHOZ
- (IL) מקבל קצה לשער קונדולי
- (BG) СТОПЕР ЗА КОНЗОЛНА ВРАТА
- (KO) 캔틸레버 게이트용 중단 정지대
- (SRB) GRANIČNIK ZA SAMONOSIVU KAPIJU

Art.	GUIDE	1pc		CODE
		kg	pcs	
LAST S	STAGE SB/SZ	1,24	2	1700005

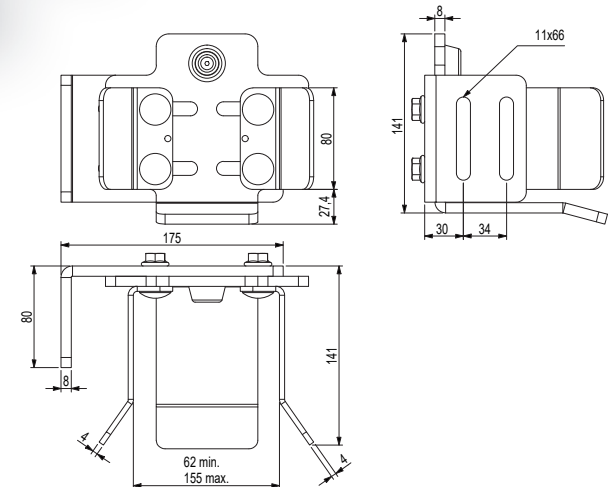
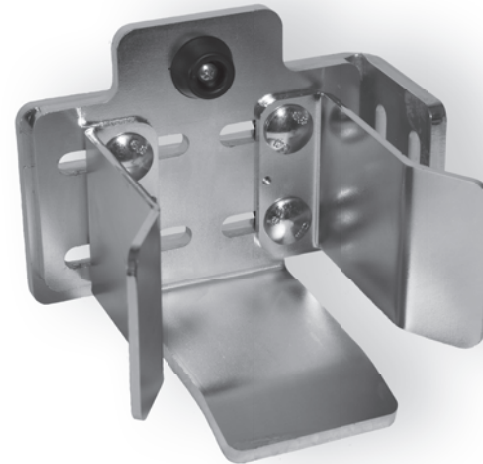

- (GB) ADJUSTABLE ALIGNMENT END STOP FOR CANTILEVER HARDWARE
- (D) VERSTELBARERAUSRICHTUNGSENDANSCHLAG FÜR CANTILEVER BESCHLÄGE
- (F) BUTÉE D'ALIGNEMENT RÉGLABLE POUR MODÈLE PORTE-À-FAUX
- (E) TOPE FINAL DE ALINEACIÓN AJUSTABLE PARA HERRAJES EN VOLADIZO
- (P) BATERIA FINAL DE ALINHAMENTO AJUSTÁVEL PARA FERRAGENS CANTILEVER
- (I) FERMO DI FINE CORSA REGOLABILE PER FERRAMENTA CANTILEVER
- (DK) JUSTERBART ENDESTOP TIL BESLAG TIL UDKRAGNING
- (NL) VERSTELBARE EINDSTOP VOOR CANTILEVER HARDWARE
- (N) JUSTERBART ENDESTOPP FOR BESLAG TIL UTLLIGGER
- (S) JUSTERBART ÄNDSTOPP FÖR BESLAG KONSOL M-MAX
- (FIN) KOHDISTUKSELTAAN SÄÄDETTÄVÄ PÄÄTYPYSÄYTIN ULKOKEPALKIN LAITTEISTOA VARTEN
- (PL) REGULOWANY OGRANICZNIK KOŃCOWY DO WYRÓWNIANIA ELEMENTÓW SYSTEMÓW WSPORNIKOWYCH TYPU
- (SK) NASTAVITELNÝ KONCOVÝ DORAZ KOVANIA SAMONOSNEJ POSUVNEJ BRÁNY
- (EE) REGULERITAV OTSAKORK TIIBVÄRAVALE
- (LT) REGULIUJAMAS IŠLYGIAVIMO GALINIS RIBOTUVAS, SKIRTAS KONSOLINIŲ VARTŲ ĮRANGAI
- (LV) REGULĒJAMS IZLĪDZINĀŠANAS GALAPUNKTS ZOBSTIEŅĀ APARATŪRAI

- (CZ) NASTAVITELNÝ KONCOVÝ DORAZ PRO KONSOLOVÉ KOVÁNÍ
- (RO) OPRITOR DE ALINIERE REGLABIL PENTRU FERONERIE CANTILEVER
- (HR) PODESIVI GRANIČNIK ZA PORAVNANJE ZA OKOV CANTILEVER
- (RUS) РЕГУЛИРУЕМЫЙ ВЫРАВНИВАЮЩИЙ КОНЦЕВОЙ УПОР ДЛЯ ФУРНИТУРЫ САМОНЕСУЩИХ ОТКАТНЫХ ВОРОТ
- (SLO) NASTAVLJIVI PORAVNALNI KONČNI OMEJEVALNIK ZA OKOVJE CANTILEVER
- (TR) KONSOL KIRIŞ S DONANIMI İÇİN AYARLANABİLİR HIZALAMA UÇ DURDURUCU
- (AR) معدن المحاذاة الطرفي القابل للضبط للتهيئة حرف S للبوابة الكابولية
- (CHN) 用于悬臂梁S五金件的可调式定位端部止动器
- (MAL) ADANG Hujung PENAJARAN BOLEH LARAS UNTUK PERKAKASAN JULUR
- (H) ÁLLÍTHATÓ ŰTKÖZŐ AZ ŰSZÖKAPU VASALATHOZ
- (IL) מעצור קצה מתכוונן לישר עבור רכיבי שער קונדולי מסוג
- (BG) РЕГУЛИРУЕМ КРАЕН ОГРАНИЧИТЕЛ ЗА ОБКОВ ЗА КОНЗОЛНИ ВРАТИ
- (KO) 캔틸레버 S 하드웨어용 조절식 정렬 엔드 스톱
- (SRB) PODESIVI GRANIČNIK ZA PORAVNANJE ZA OKOV CANTILEVER

Art.	GUIDE	1pc		CODE
		kg	pcs	
LAST SMK	STAGE SB/SZ/MB/MZ	3,75	1	1700398

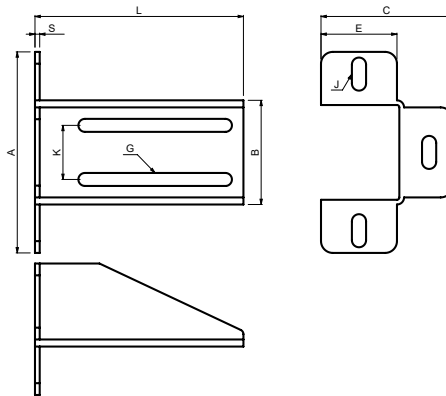
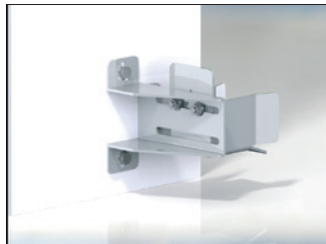

- (GB) END STOP BRACKET
- (D) KONSOLE FÜR EINLAUFSCUHH
- (F) ÉTRIER POUR BUTÉE
- (E) SOPORTE DE TOPE FINAL
- (P) SUPORTE DE BATENTE
- (I) STAFFA PER FERMO DI FINE CORSA
- (DK) ENDESTOP BESLAG
- (NL) EINDSTOP BEVESTIGINGSBEUGEL
- (N) STOPPEBRAKETT
- (S) ÄNDSTOPP KONSOL
- (FIN) PÄÄTYPYSÄYTTIMEN KANNATIN
- (PL) WSPORNİK ODBOJNIKA
- (SK) KONZOLA PRE DOJAZDOVÚ KAPSU
- (EE) OTSALÕPU KLAMBER
- (LT) GALINIO RIBOKLIO GEMBĖ
- (LV) GALA AIZTURA KRONŠTEINS

- (CZ) KONZOLA PRO DOJEZDOVOU KAPSU
- (RO) OPRITOR CURSĂ CONSOLĂ
- (HR) KONZOLA GRANIČNIKA
- (RUS) КРОНШТЕЙН УЛАВЛИВАТЕЛЯ
- (SLO) OPORNIK ZAUSTAVLJALNIKA
- (TR) UÇ TESPİT PARÇASI DİRSEĞİ
- (AR) سنادة الحاج الطرفي
- (CHN) 终点挡块支座
- (MAL) PENDAKAP PENYENDAL HUJUNG
- (H) ÜTKÖZŐ-KERET
- (IL) תופסן למקביל קצה
- (BG) СКОБА ЗА СТОПЕР
- (KO) 종단 정지대 브래킷
- (SRB) KONZOLA GRANIČNIKA

Art.	L	A	B	C	E	G	J	K	S	END STOP	1pc				CODE
												kg	pcs	kg	
	mm														
PARK	175	170	88	95	50	11X132	12X30	46	4	LAST/PADDOCK	1,11	2	2,22	1700006	
PARK 240	245	170	88	95	50	11X200	12X30	46	4	LAST/PADDOCK	1,35	2	2,7	1700196	

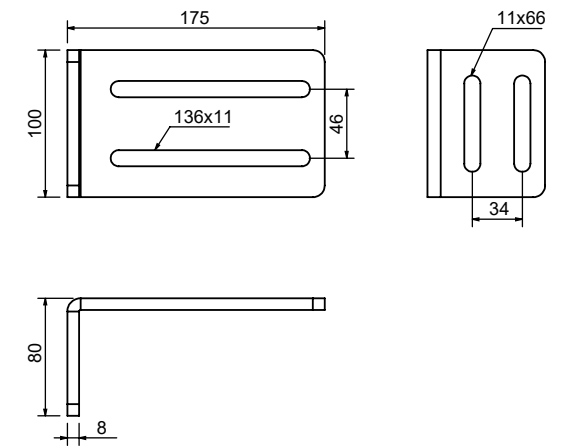
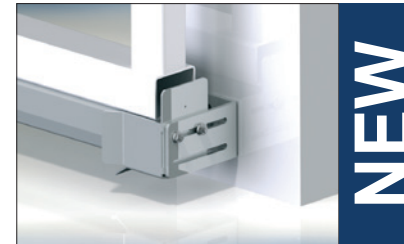
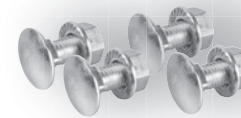

- (GB) END STOP BRACKET
- (D) KONSOLE FÜR EINLAUFSCUHH
- (F) ÉTRIER POUR BUTÉE
- (E) SOPORTE DE TOPE FINAL
- (P) SUPORTE DE BATENTE
- (I) STAFFA PER FERMO DI FINE CORSA
- (DK) ENDESTOP BESLAG
- (NL) EINDSTOP BEVESTIGINGSBEUGEL
- (N) STOPPEBRAKETT
- (S) ÄNDSTOPP KONSOL
- (FIN) PÄÄTYPYSÄYTTIMEN KANNATIN
- (PL) WSPORNİK ODBOJNIKA
- (SK) KONZOLA PRE DOJAZDOVÚ KAPSU
- (EE) OTSALÕPU KLAMBER
- (LT) GALINIO RIBOKLIO GEMBĖ
- (LV) GALA AIZTURA KRONŠTEINS

- (CZ) KONZOLA PRO DOJEZDOVOU KAPSU
- (RO) OPRITOR CURSĂ CONSOLĂ
- (HR) KONZOLA GRANIČNIKA
- (RUS) КРОНШТЕЙН УЛАВЛИВАТЕЛЯ
- (SLO) OPORNIK ZAUSTAVLJALNIKA
- (TR) UÇ TESPİT PARÇASI DİRSEĞİ
- (AR) سنادة الحاج الطرفي
- (CHN) 终点挡块支座
- (MAL) PENDAKAP PENYENDAL HUJUNG
- (H) ÜTKÖZŐ-KERET
- (IL) תופסן למקביל קצה
- (BG) СКОБА ЗА СТОПЕР
- (KO) 종단 정지대 브래킷
- (SRB) KONZOLA GRANIČNIKA

Art.	BRACKET	1pc			CODE
			kg	pcs	
PARK CSM	LAST/PADDOCK	1,36	2	2,72	1700359
PARK CSM 240	LAST/PADDOCK	1,72	2	3,44	1700399

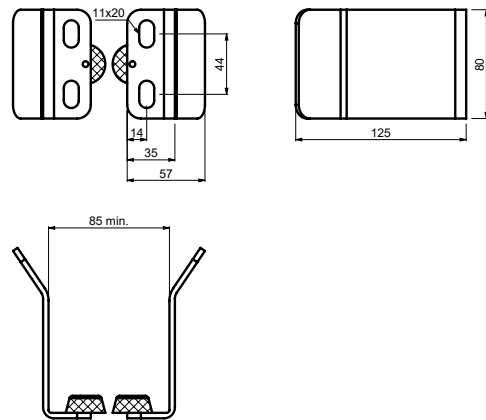
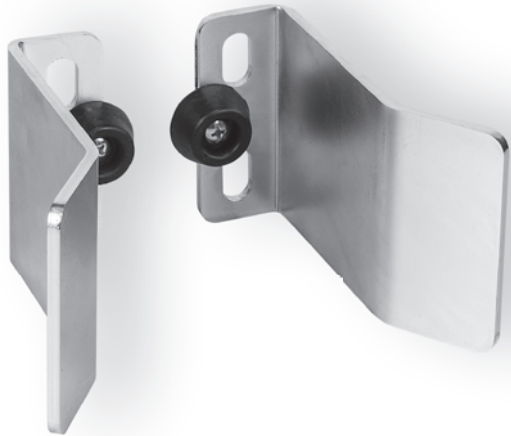

- (GB) END STOP
- (D) ENDANSCHLAG
- (F) BUTÉE
- (E) TOPE FINAL
- (P) FIM DE CORSO
- (I) ARRESTO TERMINALE
- (DK) ENDESTOP
- (NL) EINDSTOP
- (N) ENDESTOPP
- (S) ÄNDSTOPP
- (FIN) RAJOITIN
- (PL) ZDERZAK KRAŃCOWY
- (SK) DORAZ
- (EE) OTSA LÕPPR
- (LT) GALINIS RIBOKLIS
- (LV) GALA AIZTURIS

- (CZ) KONCOVÝ DORAZ
- (RO) OPRITOR FINAL
- (HR) GRANIČNIK
- (RUS) КОНЦЕВОЙ УПОР
- (SLO) KONČNI ELEMENT
- (TR) UÇ TIPASI
- (AR) نقطة التوقف
- (CHN) 限位挡块
- (MAL) ADANG Hujung
- (H) VÉGÜTKÖZŐ
- (IL) מקבל קצה
- (BG) СТОПЕР
- (KO) 종단 장치대
- (SRB) GRANIČNIK

Art.	BRACKET	1pc		CODE
		kg	pcs	
PADDOCK SM	PARK/PARK 240/ PARK CSM	0,78	2	1700194

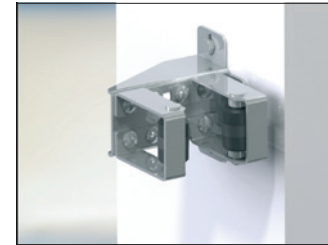
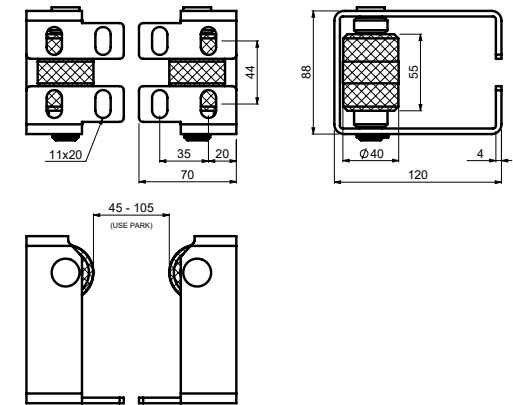
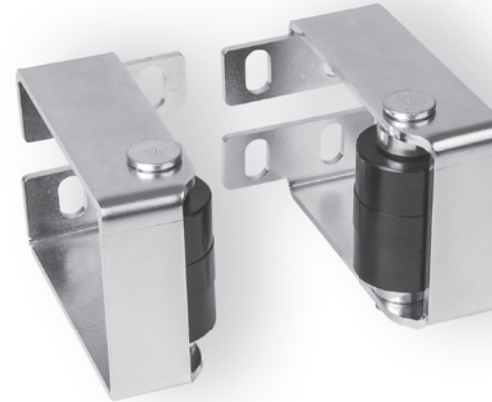

- (GB) END STOP WITH ROLLER
- (D) ENDANSCHLAG MIT ROLLE
- (F) BUTÉE AVEC ROULEAU
- (E) TOPE FINAL CON RODILLO
- (P) FIM DE CORSO COM ROLO
- (I) ARRESTO TERMINALE CON RULLO
- (DK) ENDESTOP MED VALSE
- (NL) EINDSTOP MET ROLLEN
- (N) ENDESTOPP MED RULLE
- (S) ÄNDSTOPP MED RULLE
- (FIN) RAJOITIN RULLALLA
- (PL) ZDERZAK KRAŃCOWY Z ROLKĄ
- (SK) DORAZ S VALČEKOM
- (EE) OTSALÕPP RULLIKUGA
- (LT) GALINIS RIBOKLIS SU RITINĖLIU
- (LV) GALA AIZTURIS AR RULLĪTI

- (CZ) KONCOVÝ DORAZ S Kladkou
- (RO) OPRITOR FINAL CU ROLĂ
- (HR) GRANIČNIK S VALJKOM
- (RUS) КОНЦЕВОЙ УПОР С РОЛИКОМ
- (SLO) KONČNI ELEMENT S KOLESCEM
- (TR) MAKARALI UÇ TIPASI
- (AR) نقطة التوقف المزودة بكرة
- (CHN) 帶轆子的限位擋塊
- (MAL) ADANG Hujung DENGAN PENGGELEK
- (H) VÉGÜTKÖZŐ GÖRGŐVEL
- (IL) מקבל מתחנן עם גלגלי ארוקולין
- (BG) СТОПЕР С РОЛКА
- (KO) 롤러가 있는 종단 장치대
- (SRB) GRANIČNIK SA VALJKOM

Art.	BRACKET	1pc		CODE
		kg	pcs	
PADDOCK 2	PARK/PARK 240/ PARK CSM	1,4	2	1700182



CAIS INNOVATION

FAIL-SAFE
ROLLER MECHANISM

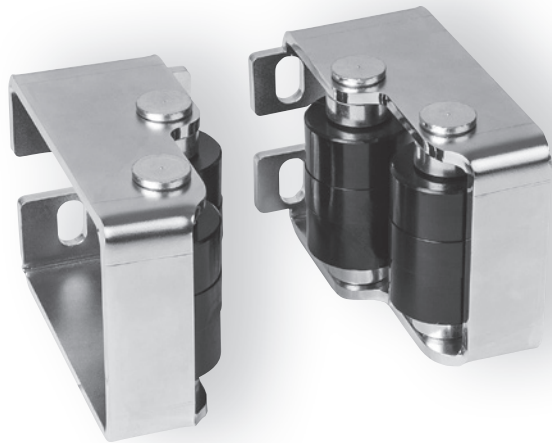

CAIS INNOVATION

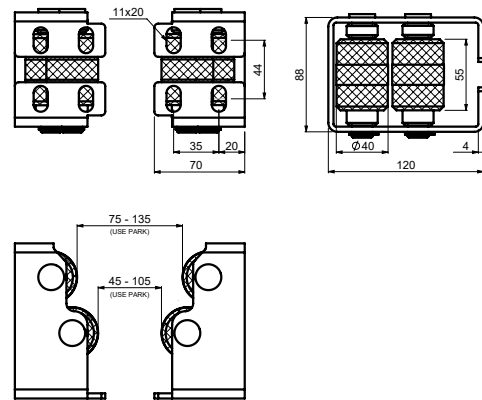
FAIL-SAFE
ROLLER MECHANISM

(GB) END STOP WITH ROLLER
 (D) ENDANSCHLAG MIT ROLLE
 (F) BUTÉE AVEC ROULEAU
 (E) TOPE FINAL CON RODILLO
 (P) FIM DE CURSO COM ROLO
 (I) ARRESTO TERMINALE CON RULLO
 (DK) ENDESTOP MED VALSE
 (NL) EINDSTOP MET ROLLEN
 (N) ENDESTOPP MED RULLE
 (S) ÄNDSTOPP MED RULLE
 (FIN) RAJOITIN RULLALLA
 (PL) ZDERZAK KRAŃCOWY Z ROLKĄ
 (SK) DORAZ S VALČEKOM
 (EE) OTSALÖPP RULLIKUGA
 (LT) GALINIS RIBOKLIS SU RITINĖLIU
 (LV) GALA AIZTURIS AR RULLĪTI

(CZ) KONCOVÝ DORAZ S KLDKOU
 (RO) OPRITOR FINAL CU ROLĂ
 (HR) GRANIČNIK S VALJKOM
 (RU) КОНЦЕВОЙ УПОР С РОЛИКОМ
 (SLO) KONČNI ELEMENT S KOLESCEM
 (TR) MAKARALI UÇ TIPASI
 (AR) نقطة التوقف المزودة ببنكره
 (CHN) 帶轆子的限位擋塊
 (MAL) ADANG Hujung DENGAN PENGGELEK
 (H) VÉGÜTKÖZŐ GÖRGŐVEL
 (IL) מקבל מתכוונן עם גלגלי אוקולין
 (BG) СТОПЕР С РОЛКА
 (KO) 롤러가 있는 종단 정지대
 (SRB) GRANIČNIK SA VALJKOM

Art.	BRACKET	1pc			CODE
		kg	pc	kg	
PADDOCK 4	PARK/PARK 240/ PACK CSM	2,1	1	2,1	1700191

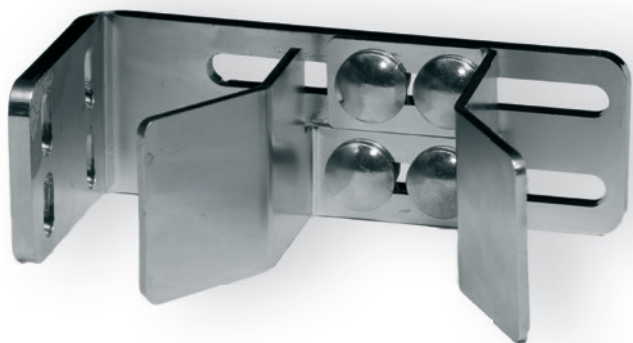

CAIS INNOVATION

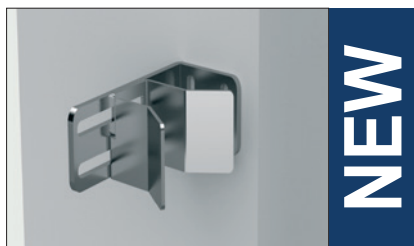
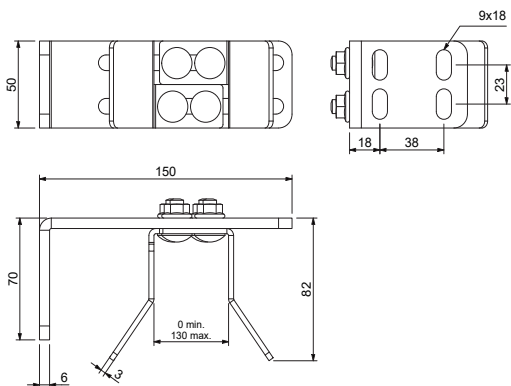

- (GB) ADJUSTABLE END STOP BRACKET
- (D) VERSTELLBARER ENDANSCHLAGWINKEL
- (F) SUPPORT D'EXTRÉMITÉ RÉGLABLE
- (E) TOPE DE DETENCIÓN AJUSTABLE
- (P) SUPORTE DE PARADA AJUSTÁVEL
- (I) STAFFA REGOLABILE DI FINE CORSA
- (DK) JUSTERBART ENDESTOPBESLAG
- (NL) INSTELBARE EINDSTOPBEUGEL
- (N) JUSTERBAR ENDESTOPBRACKET
- (S) JUSTERBAR ÄNDSTOPPSKONSOL
- (FIN) SAÄDETTÄVÄ RAJOITTIMEN KANNATIN
- (PL) KOŃCOWY WSPORNIK Z REGULACJĄ
- (SK) NASTAVITELNÁ KONZOLA KONCOVÉHO DORAZU
- (EE) REGULEERITAVA OTSATÕKESTIGA KANDUR
- (LT) REGULIUOJAMOJI GALINIO RIBOKLIO GEMBĖ
- (LV) REGULĒJAMS KRONŠTEINA VEIDA GALA AIZTURIS

- (CZ) KONCOVÝ DORAZ S KONZOLOU
- (RO) CONSOLĂ REGLABILĂ DE CAPĂT
- (HR) PRILAGODLJIVI NOSAČ GRANIČNIKA
- (RUS) РЕГУЛИРУЕМЫЙ КРОНШТЕЙН КОНЦЕВОГО УПОРА
- (SLO) NASTAVLJIVA ZAUSTAVITVENA ROČICA
- (TR) AYARLANABİLİR UÇ TESPİT BRKETİ
- (AR) كتبة سادة طرفية قابلة للتعديل
- (CHN) 可调终点挡架
- (MAL) PENDAKAP ADANG HUIJUNG BOLEH LARAS
- (H) ÁLLÍTHATÓ VÉGÜTKÖZŐ KONZOL
- (IL) סוגר עיצירה סופי הניתן לכווון
- (BG) РЕГУЛИРУЕМА КРАЙНА ОГРАНИЧИТЕЛНА СКОБА
- (KO) 조절식 연드 스톱 브래킷
- (SRB) PODESIVI NOSAČ SA GRANIČNIKOM

Art.	1pc			CODE	
		kg	pcs		kg
DOCKER O	0,67		4	2,68	1700367

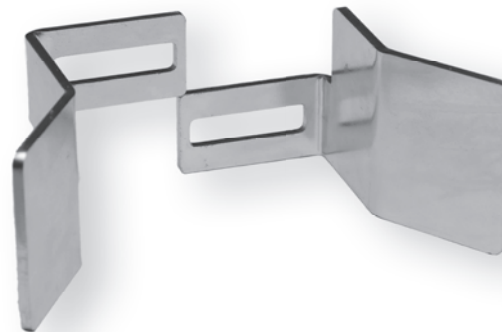

CAIS INNOVATION

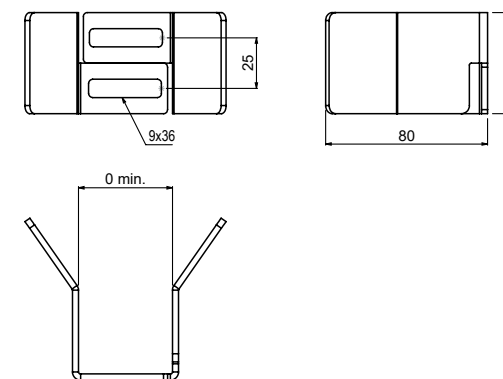

- (GB) ADJUSTABLE END STOP
- (D) ENDANSCHLAG
- (F) BUTÉE
- (E) TOPE FINAL
- (P) FIM DE CORSO
- (I) ARRESTO TERMINALE
- (DK) ENDESTOP
- (NL) EINDSTOP
- (N) ENDESTOPP
- (S) ÄNDSTOPP
- (FIN) RAJOITIN
- (PL) ZDERZAK KRAŃCOWY
- (SK) DORAZ
- (EE) OTSA LÕPPR
- (LT) GALINIS RIBOKLIS
- (LV) GALA AIZTURIS

- (CZ) KONCOVÝ DORAZ
- (RO) OPRITOR FINAL
- (HR) GRANIČNIK
- (RUS) КОНЦЕВОЙ УПОР
- (SLO) KONČNI ELEMENT
- (TR) UÇ TIPASI
- (AR) نقطة التوقف
- (CHN) 限位挡块
- (MAL) ADANG HUIJUNG
- (H) VÉGÜTKÖZŐ
- (IL) מקבל קצה
- (BG) СТОПЕР
- (KO) 종단 정지대
- (SRB) GRANIČNIK

Art.	BRACKET	1pc			CODE
			kg	pcs	
PADDOCK O	COLUMN	0,22	10	2,2	1700351

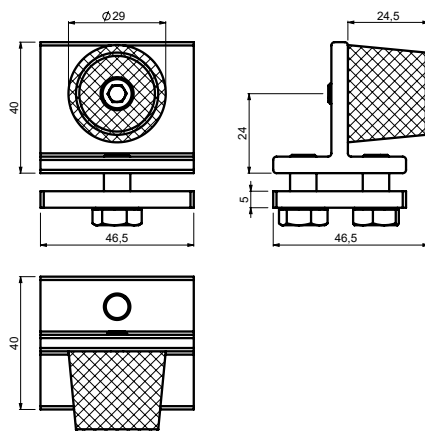
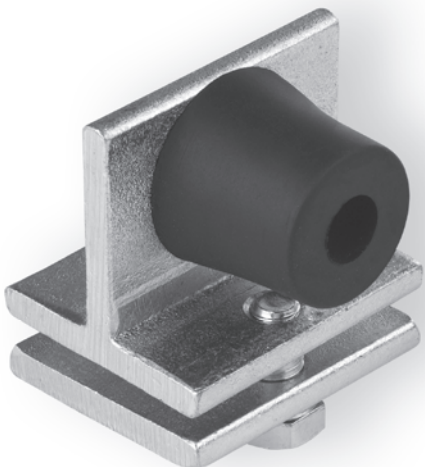

- (GB) INTERNAL GUIDE END STOP
- (D) INNENANSCHLAG FÜR „C“ PROFIL
- (F) BUTÉE INTERNE POUR GUIDE
- (E) TOPE FINAL DE GUÍA INTERNA
- (P) BATENTE GUIA INTERNA
- (I) FERMO DI FINE CORSA DELLA GUIDA INTERNA
- (DK) INTERN VANGEENDESTOP
- (NL) INTERNE GELEIDER EINDSTOP
- (N) ENDESTOPPER TIL INNVEDIG SKINNE
- (S) INTERNT GEJÄNDSTOPP
- (FIN) SISÄINEN OHJAIMEN PÄÄN PYSÄYTIN
- (PL) WEWNĘTRZNY ODBOJNIK SZYNY
- (SK) DORAZ VNÚTORNÝ PRE NOSNÝ „C“ PROFIL
- (EE) SISEJUHIKU OTSALOPP
- (LT) VIDINIO KREIPTUVO GALINIS RIBOKLIS
- (LV) IEKŠĒJAIS VADOTNES GALA AIZTURIS

- (CZ) DORAZ VNITŘNÍ PRO ŠINU „C“ PROFIL
- (RO) GHIDAJ CAPĂT FINAL INTERN
- (HR) UNUTARNJI GRANIČNIK VODILICE
- (RUS) ВНУТРЕННИЙ ОГРАНИЧИТЕЛЬ НАПРАВЛЯЮЩЕГО РЕЛЬСА «С»
- (SLO) ZAUSTAVLJALNIK NOTRANJEGA VODILA
- (TR) DAHİLİ KIZAK UÇ TESPİT PARÇASI
- (AR) مقع طرفي لتعليق داخلي
- (CHN) 内导轨终点挡块
- (MAL) PENYENDAL Hujung PANDU DALAM
- (H) VEZETŐSÍN BELSŐ ÜTKÖZŐ
- (IL) מעצור פנימי גומי לקרונה
- (BG) ВЪТРЕШЕН СТОПЕР ЗА РЕЛСА
- (KO) 내부 가이드 종단 정지대
- (SRB) UNUTRAŠNJI GRANIČNIK VOĐICE

Art.	GUIDE	1pc		CODE
		kg	pcs	
FINISH S	STAGE SB/SZ	0,23	20	1700008

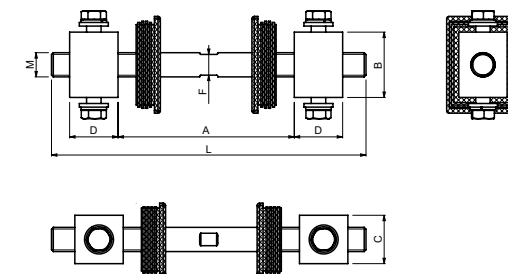
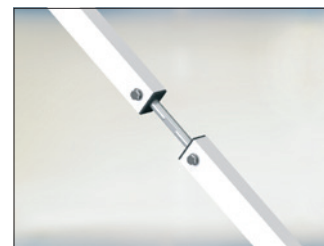
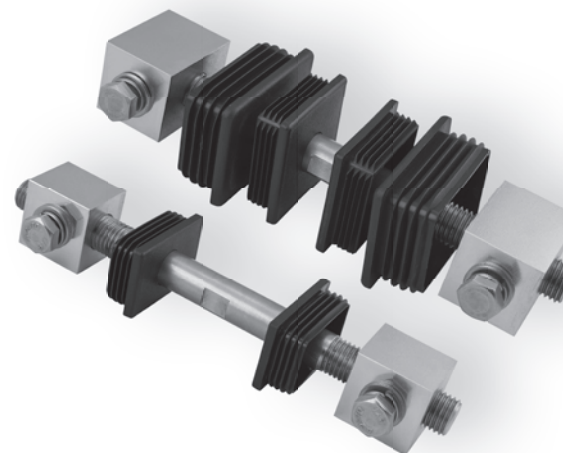

- (GB) ADJUSTABLE TENSION BAR FOR CANTILEVER GATE
- (D) EINSTELLBARE ZUGSTANGE FÜR AUSLEGERTOR
- (F) BARRE DE TENSION RÉGLABLE POUR PORTAIL COULISSANT AUTOPORTANT
- (E) BARRA TENSORA AJUSTABLE PARA PORTÓN EN VOLADIZO
- (P) BARRA DE TENSÃO AJUSTÁVEL PARA PORTÃO CANTILEVER
- (I) TIRANTE DI REGOLAZIONE PER CANCELLO AUTOPORTANTE
- (DK) JUSTERBAR SPÆNDINGSSTANG TIL FRITBÆRENDE PORT
- (NL) VERSTELBARE SPANNINGSBALK VOOR SCHUIFPOORT
- (N) JUSTERBAR STREKKSTANG FOR RULLEPORT
- (S) JUSTERBAR SPÄNNINGSSTÅNG FÖR FRIBÄRANDE GRIND
- (FIN) SÄÄDETTÄVÄ KIRISTYSTANKO ULOKEPORTTIIN
- (PL) REGULOWANA LISTWA NAPINAJĄCA DO BRAMY SAMONOŚNEJ
- (SK) NASTAVITELNÁ ŤAŽNÁ TYČ PRE SAMONOŠNÉ BRÁNY
- (EE) REGULEERITAV PINGUTUSTALA KONSOLVÄRAVA JAOKS
- (LT) REGULIUOJAMA TRAUKĖ GEMBINIAMS VARTAMS
- (LV) REGULĒJAMS STIEPNIS KONSOLVEIDA VĀRTIEM

- (CZ) TENZNÍ TYČ S REGULACÍ PRO POSUVNOU SAMONOSNOU BRÁNU
- (RO) BARĂ DE TENSIUNE REGLABILĂ PENTRU POARTĂ ÎN CONSOLĂ
- (HR) PRILAGODLJIVA STEZNA ŠIPKA ZA NOSIVA VRATA
- (RUS) РЕГУЛИРУЕМЫЙ РАСТЯНУТЫЙ СТЕРЖЕНЬ ДЛЯ САМОНЕСУЩИХ ВОРОТ
- (SLO) NASTAVLJIV NAPENJALNI VZVOD ZA SAMONOSNA DRSNNA VRATA
- (TR) MANİVELA KAPI İÇİN AYARLANABİLİR GERİLİM ÇUBUĞU
- (AR) قضيب الشد القابل للتعديل لوابية الكابول
- (CHN) 可调节悬臂门拉杆
- (MAL) BAR TEGANGAN BOLEH LARAS UNTUK GET JULUR
- (H) ÁLLÍTHATÓ FESZÍTŐRÚD TOLÓKAPUHOZ
- (IL) מוט מתיחה מתכוונן לשיער קונולי
- (BG) РЕГУЛИРУЕМ ОБТЕГАЧ ЗА КОНЗОЛНА ВРАТА
- (KO) 캔틸레버 게이트용 조절식 인장대
- (SRB) PODESIVA ZATEZNA ŠIPKA ZA SAMONOSIVU KAPIJU

Art.	L	A min./max.	B	C	D	M	F	1pc			CODE	
								kg	pcs	kg		
DIAGON 60	60x40	260	125 - 170	34	40	40	M20	17	1,39	2	2,78	1700237
DIAGON 80	80x60/60x60	260	125 - 180	54	40	40	M20	17	1,95	2	3,9	1700238

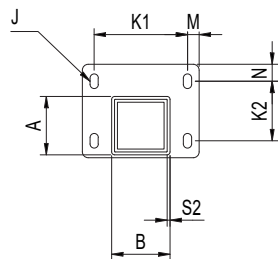
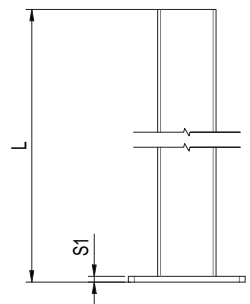

- (GB) STEEL GATE SUPPORT POST
- (D) STAHL-TORPFOSTEN
- (F) POTEAU DE RENFORT POUR PORTAIL ACIER
- (E) POSTE DE ACERO PARA CANCELAS
- (P) PILAR DE SUPORTE DO PORTÃO EM AÇO
- (I) MONTANTE DI SUPPORTO PER CANCELLO IN ACCIAIO
- (DK) STØTTESTOLPE TIL PORT I STÅL
- (NL) STALEN STAANDER
- (N) STØTTESTOLPE FOR PORT I STÅL
- (S) STÖDPOST FÖR STÅLGRIND
- (FIN) TERÄKSINEN PORTIN TUUKIPYLÄS
- (PL) STALOWY SŁUPEK PODTRZYMUJĄCY BRAMĘ
- (SK) OCELOVÝ NOSNÝ STĽP BRÁNY
- (EE) TERASVÄRAVA TUGIPOST
- (LT) PLIENINIS VARTŲ ATRAMINIS STULPELIS
- (LV) TĒRAUDA VĀRTU ATBALSTA STABS

- (CZ) OCELOVÝ PODPĚRNÝ SLOUPEK BRÁNY
- (RO) STĂLP DE SUSȚINERE PENTRU POARTĂ DIN OȚEL
- (HR) ČELIČNI POTPORNI STUP ZA VRATA
- (RUS) СТАЛЬНАЯ ОПОРНАЯ СТОЙКА ДЛЯ ВОРОТ
- (SLO) JEKLENI NOSILNI STEBER ZA VRATA
- (TR) ÇELİK KAPI DESTEK DİRÉĐİ
- (AR) عمود تدعيم البوابة الفولاذي
- (CHN) 铁门支撑柱
- (MAL) TIANG SOKONGAN PAGAR KELULI
- (H) ACÉL KAPUTARTÓ OSZLOP
- (IL) עמוד תומך לשיער מפלדה
- (BG) СТОМАНЕНА ОПОРНА КОЛОНА ЗА ПОРТА
- (KO) 강철 게이트 지지대
- (SRB) ČELIČNI POTPORNI STUP ZA VRATA

Art.	L	A	B	M	N	K1	K2	S1	S2	1pc	Image		CODE
											kg	pcs	
mm													
TOWER 1.1	1100	100	100	20	29,5	160	101	10	3	12	1	12	1710803
TOWER 1.3	1300	100	100	20	29,5	160	101	10	3	13,5	1	13,5	1710804
TOWER 1.5	1500	100	100	20	29,5	160	101	10	3	15	1	15	1710805
TOWER 1.8	1800	100	100	20	29,5	160	101	10	3	17,5	1	17,5	1710807

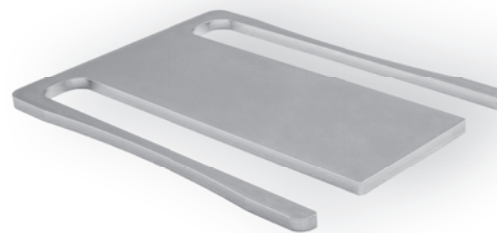

- (GB) WASHER FOR CANTILEVER CARRIAGE
- (D) UNTERLEGSCHIBE FÜR AUSLEGERSCHLITTEN
- (F) RONDELLE POUR CHARIOT CANTILEVER
- (E) TUERCA PARA CARRO EN VOLADIZO
- (P) ARRUELA PARA TRANSPORTE DE CANTILEVER
- (I) RONDELLA PER CARRELLO CANCELLO AUTOPORTANTE
- (DK) SKIVE TIL FRITVÆRENDE PORT
- (NL) RING VOOR SCHUIFWAGEN
- (N) SKIVE FOR RULLEPORTVOGN
- (S) BRICKA FÖR FRIBÄRANDE GRINDVAGN
- (FIN) ALUSLEVY ULOKETELINEESEEN
- (PL) PODKŁADKA DO WÓZKA BRAMY SAMONOŚNEJ
- (SK) PODLOŽKA PRE SAMONOSNÝ NOSNÍK
- (EE) SEIB KONSOOLALUSE JAKKS
- (LT) POVERŽLĖ GEMBINIŲ VARTŲ VEŽIMĖLIUI
- (LV) PAPLĀKSNE KONSOLES NESOŠAJAM RUĻĻU BLOKAM

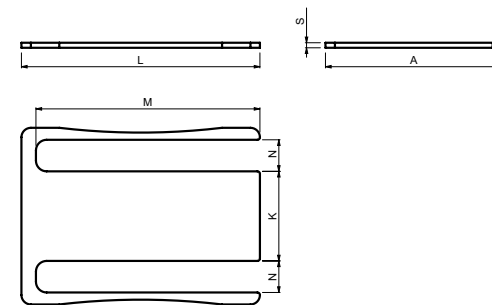

- (CZ) PODLOŽKA PRO VOZÍK
- (RO) ȘAIBĂ PENTRU SISTEMUL DE CULISARE ÎN CONSOLĂ
- (HR) PODLOŠKA ZA NOSIVO PODVOZJE
- (RUS) ШАЙБА ДЛЯ РОЛИКОВЫХ ТЕЛЕЖЕК САМОНЕСУЩИХ ВОРОТ
- (SLO) PODLOŽKA ZA VOZIČEK
- (TR) MANİVELA TAŞIYICISI İÇİN RONDELA
- (AR) حلقة لتواية الكترول
- (CHN) 悬臂架垫片
- (MAL) SESENDAL UNTUK PEMBAWA JULUR
- (H) ALÁTÉT TOLÓKAPU FUTÓKOSIHOZ
- (IL) הקט לתלולים לקומולי
- (BG) ВЛОЖКА ЗА КОНЗОЛНА КОЛИЧКА
- (KO) 캔틸레버 이송대용 와셔
- (SRB) PODLOŠKA ZA SAMONOSIVU KAPIJU

Art.	L	A	K	M	N	S	CARRIAGE	1pc	Image		CODE
									kg	pcs	
mm											
DESK SE 2	189	140	71	178	25	2	SPEED SE	0,26	6	1,56	1700314
DESK SE 4	189	140	71	178	25	4	SPEED SE	0,52	6	3,12	1700315
DESK SE 6	189	140	71	178	25	6	SPEED SE	0,78	6	4,68	1700316

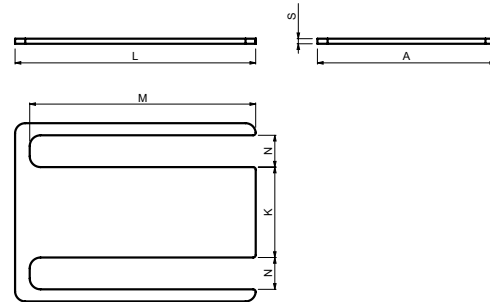
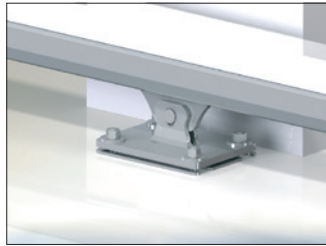
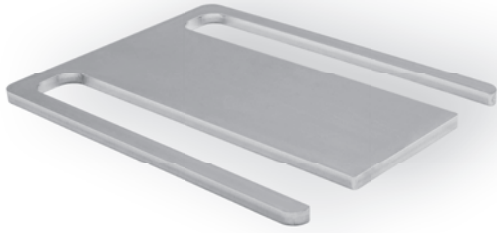

- (GB) WASHER FOR CANTILEVER CARRIAGE
- (D) UNTERLEGSCHIBE FÜR AUSLEGERSCHLITTEN
- (F) RONDELLE POUR CHARIOT CANTILEVER
- (E) TUERCA PARA CARRO EN VOLADIZO
- (P) ARRUELA PARA TRANSPORTE DE CANTILEVER
- (I) RONDELLA PER CARRELLO CANCELLO AUTOPORTANTE
- (DK) SKIVE TIL FRITBÆRENDE PORT
- (NL) RING VOOR SCHUIFWAGEN
- (N) SKIVE FOR RULLEPORTVOGN
- (S) BRICKA FÖR FRIBÄRANDE GRINDVAGN
- (FIN) ALUSLEVY ULOKETELINEESEEN
- (PL) PODKŁADKA DO WÓZKA BRAMY SAMONOSNEJ
- (SK) PODLOŽKA PRE SAMONOSNÝ NOSNÍK
- (EE) SEIB KONSOLALUSE JAOKS
- (LT) POVERŽLĖ GEMBINIŲ VARTŲ VEŽIMĖLIUI
- (LV) PĀPLĀKSNE KONSOLĒS NESOŠĀJAM RULĻU BLOKAM

- (CZ) PODLOŽKA PRO VOZÍK
- (RO) ȘAIBĂ PENTRU SISTEMUL DE CULISARE ÎN CONSOLĂ
- (HR) PODLOŠKA ZA NOSIVO PODVOZJE
- (RUS) ШАЙБА ДЛЯ РОЛИКОВЫХ ТЕЛЕЖЕК САМОНЕСУЩИХ ВОРОТ
- (SLO) PODLOŽKA ZA VOZIČEK
- (TR) MANİVELA TAŞIYICISI İÇİN RONDELA
- (AR) حلبة لواءة الكترول
- (CHN) 悬臂架垫片
- (MAL) SESENDAL UNTUK PEMBAWA JULUR
- (H) ALÁTÉT TOLÓKAPU FUTÓKOCSIHOZ
- (IL) הקטלוג ללואות הקרונית
- (BG) ВЛОЖКА ЗА КОНЗОЛНА КОЛИЧКА
- (KO) 캔틸레버 이송대용 와셔
- (SRB) PODLOŠKA ZA SAMONOSIVU KAPJIJU

Art.	L	A	K	M	N	S	CARRIAGE	1pc	CARRIAGE			CODE
								kg	pcs	kg	kg	
									mm			
DESK S 2	189	140	71	178	25	2	SPEED S	0,29	6	1,74		1700317
DESK S 4	189	140	71	178	25	4	SPEED S	0,58	6	3,48		1700318
DESK S 6	189	140	71	178	25	6	SPEED S	0,87	6	5,22		1700319

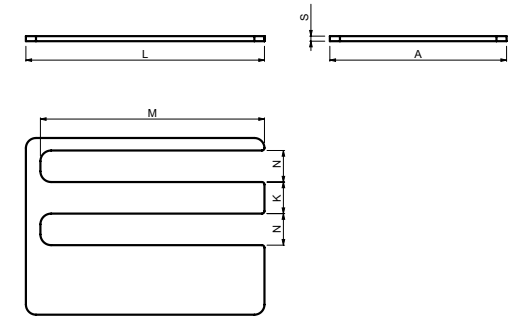
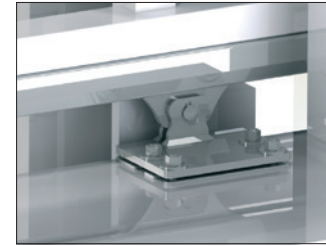
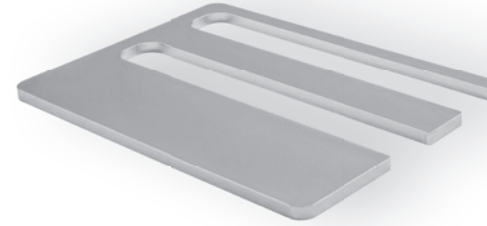

- (GB) WASHER FOR CANTILEVER CARRIAGE
- (D) UNTERLEGSCHIBE FÜR AUSLEGERSCHLITTEN
- (F) RONDELLE POUR CHARIOT CANTILEVER
- (E) TUERCA PARA CARRO EN VOLADIZO
- (P) ARRUELA PARA TRANSPORTE DE CANTILEVER
- (I) RONDELLA PER CARRELLO CANCELLO AUTOPORTANTE
- (DK) SKIVE TIL FRITBÆRENDE PORT
- (NL) RING VOOR SCHUIFWAGEN
- (N) SKIVE FOR RULLEPORTVOGN
- (S) BRICKA FÖR FRIBÄRANDE GRINDVAGN
- (FIN) ALUSLEVY ULOKETELINEESEEN
- (PL) PODKŁADKA DO WÓZKA BRAMY SAMONOSNEJ
- (SK) PODLOŽKA PRE SAMONOSNÝ NOSNÍK
- (EE) SEIB KONSOLALUSE JAOKS
- (LT) POVERŽLĖ GEMBINIŲ VARTŲ VEŽIMĖLIUI
- (LV) PĀPLĀKSNE KONSOLĒS NESOŠĀJAM RULĻU BLOKAM

- (CZ) PODLOŽKA PRO VOZÍK
- (RO) ȘAIBĂ PENTRU SISTEMUL DE CULISARE ÎN CONSOLĂ
- (HR) PODLOŠKA ZA NOSIVO PODVOZJE
- (RUS) ШАЙБА ДЛЯ РОЛИКОВЫХ ТЕЛЕЖЕК САМОНЕСУЩИХ ВОРОТ
- (SLO) PODLOŽKA ZA VOZIČEK
- (TR) MANİVELA TAŞIYICISI İÇİN RONDELA
- (AR) حلبة لواءة الكترول
- (CHN) 悬臂架垫片
- (MAL) SESENDAL UNTUK PEMBAWA JULUR
- (H) ALÁTÉT TOLÓKAPU FUTÓKOCSIHOZ
- (IL) הקטלוג ללואות הקרונית
- (BG) ВЛОЖКА ЗА КОНЗОЛНА КОЛИЧКА
- (KO) 캔틸레버 이송대용 와셔
- (SRB) PODLOŠKA ZA SAMONOSIVU KAPJIJU

Art.	L	A	K	M	N	S	CARRIAGE	1pc	CARRIAGE			CODE
								kg	pcs	kg	kg	
									mm			
DESK SK 2	189	140	25	178	25	2	SPEED SK	0,27	6	1,62		1700320
DESK SK 4	189	140	25	178	25	4	SPEED SK	0,54	6	3,24		1700321
DESK SK 6	189	140	25	178	25	6	SPEED SK	0,81	6	4,86		1700322

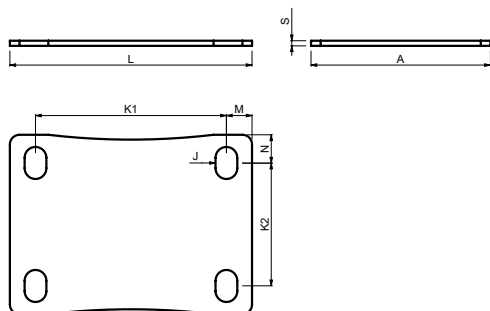
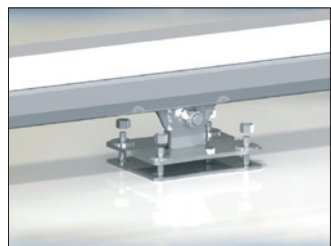
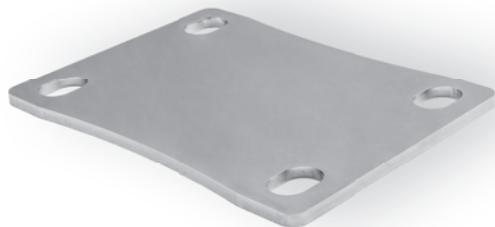

- (GB) WASHER FOR CANTILEVER CARRIAGE
- (D) UNTERLEGSCHIEBE FÜR AUSLEGERSCHLITTEN
- (F) RONDELLE POUR CHARIOT CANTILEVER
- (E) TUERCA PARA CARRO EN VOLADIZO
- (P) ARRUELA PARA TRANSPORTE DE CANTILEVER
- (I) RONDELLA PER CARRELLO CANCELLO AUTOPORTANTE
- (DK) SKIVE TIL FRITBÆRENDE PORT
- (NL) RING VOOR SCHUIFWAGEN
- (N) SKIVE FOR RULLEPORTVOGN
- (S) BRICKA FÖR FRIBÄRANDE GRINDVAGN
- (FIN) ALUSLEVY ULOKETELINEESEN
- (PL) PODKLADKA DO WÓZKA BRAMY SAMONOŚNEJ
- (SK) PODLOŽKA PRE SAMONOSNÝ NOSNÍK
- (EE) SEIB KONSOOLALUSE JAOKS
- (LT) POVERŽLĖ GEMBINIŲ VARTŲ VEŽIMĖLIUI
- (LV) PĀPLĀKSNE KONSOLĒS NESOŠĀJAM RULĻU BLOKAM

- (CZ) PODLOŽKA PRO VOZÍK
- (RO) ȘAIBĂ PENTRU SISTEMUL DE CULISARE ÎN CONSOLĂ
- (HR) PODLOŠKA ZA NOSIVO PODVOZJE
- (RUS) ШАЙБА ДЛЯ РОЛИКОВЫХ ТЕЛЕЖЕК САМОНЕСУЩИХ ВОРОТ
- (SLO) PODLOŽKA ZA VOZIČEK
- (TR) MANIVELA TAŞIYICISI İÇİN RONDELA
- (AR) حطة لولاية الكترول
- (CHN) 悬臂架垫片
- (MAL) SESENDAL UNTUK PEMBAWA JULUR
- (H) ALÁTÉT TOLÓKAPU FUTÓKOCSIHOZ
- (IL) קרקע לגלגלים קרונווליי
- (BG) ВЛОЖКА ЗА КОНЗОЛНА КОЛИЧКА
- (KO) 캔틸레버 이송대용 와셔
- (SRB) PODLOŠKA ZA SAMONOSIVU KARIJU

Art.	L	A	J	K1	K2	M	N	S	CARRIAGE	1pc	📦			CODE
										kg	pcs	kg		
mm											kg	pcs	kg	
RAMP SE 2	189	140	17x25	149	96	20	22	2	SPEED SE	0,38	6	2,28	1700283	
RAMP SE 4	189	140	17x25	149	96	20	22	4	SPEED SE	0,75	6	4,5	1700284	
RAMP SE 6	189	140	17x25	149	96	20	22	6	SPEED SE	1,08	6	6,48	1700285	

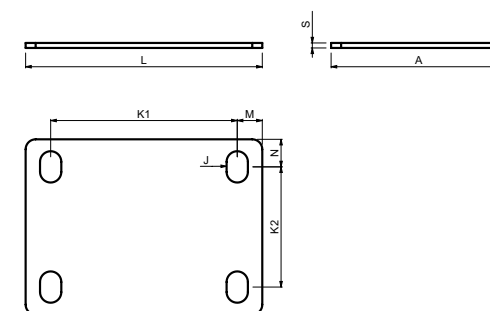
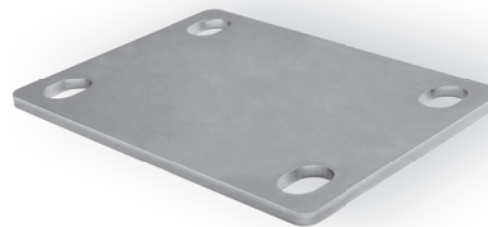

- (GB) WASHER FOR CANTILEVER CARRIAGE
- (D) UNTERLEGSCHIEBE FÜR AUSLEGERSCHLITTEN
- (F) RONDELLE POUR CHARIOT CANTILEVER
- (E) TUERCA PARA CARRO EN VOLADIZO
- (P) ARRUELA PARA TRANSPORTE DE CANTILEVER
- (I) RONDELLA PER CARRELLO CANCELLO AUTOPORTANTE
- (DK) SKIVE TIL FRITBÆRENDE PORT
- (NL) RING VOOR SCHUIFWAGEN
- (N) SKIVE FOR RULLEPORTVOGN
- (S) BRICKA FÖR FRIBÄRANDE GRINDVAGN
- (FIN) ALUSLEVY ULOKETELINEESEN
- (PL) PODKLADKA DO WÓZKA BRAMY SAMONOŚNEJ
- (SK) PODLOŽKA PRE SAMONOSNÝ NOSNÍK
- (EE) SEIB KONSOOLALUSE JAOKS
- (LT) POVERŽLĖ GEMBINIŲ VARTŲ VEŽIMĖLIUI
- (LV) PĀPLĀKSNE KONSOLĒS NESOŠĀJAM RULĻU BLOKAM

- (CZ) PODLOŽKA PRO VOZÍK
- (RO) ȘAIBĂ PENTRU SISTEMUL DE CULISARE ÎN CONSOLĂ
- (HR) PODLOŠKA ZA NOSIVO PODVOZJE
- (RUS) ШАЙБА ДЛЯ РОЛИКОВЫХ ТЕЛЕЖЕК САМОНЕСУЩИХ ВОРОТ
- (SLO) PODLOŽKA ZA VOZIČEK
- (TR) MANIVELA TAŞIYICISI İÇİN RONDELA
- (AR) حطة لولاية الكترول
- (CHN) 悬臂架垫片
- (MAL) SESENDAL UNTUK PEMBAWA JULUR
- (H) ALÁTÉT TOLÓKAPU FUTÓKOCSIHOZ
- (IL) קרקע לגלגלים קרונווליי
- (BG) ВЛОЖКА ЗА КОНЗОЛНА КОЛИЧКА
- (KO) 캔틸레버 이송대용 와셔
- (SRB) PODLOŠKA ZA SAMONOSIVU KARIJU

Art.	L	A	J	K1	K2	M	N	S	CARRIAGE	1pc	📦			CODE
										kg	pcs	kg		
mm											kg	pcs	kg	
RAMP S 2	189	140	17x25	149	96	20	22	2	SPEED S	0,4	6	2,4	1700286	
RAMP S 4	189	140	17x25	149	96	20	22	4	SPEED S	0,78	6	4,68	1700287	
RAMP S 6	189	140	17x25	149	96	20	22	6	SPEED S	1,13	6	6,78	1700288	

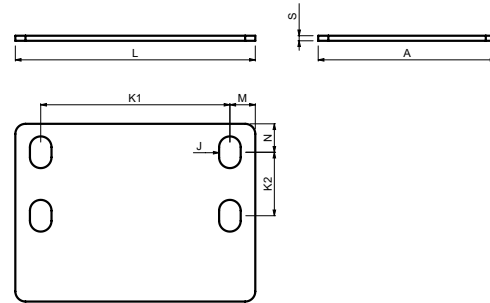
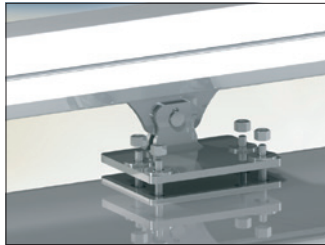
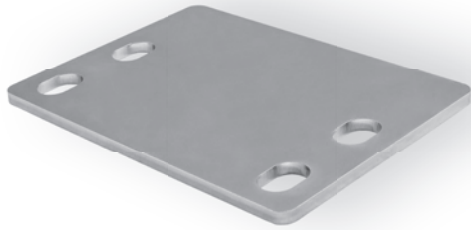

- (GB) WASHER FOR CANTILEVER CARRIAGE
- (D) UNTERLEGSCHLEIBE FÜR AUSLEGERSCHLITTEN
- (F) RONDELLE POUR CHARIOT CANTILEVER
- (E) TUERCA PARA CARRO EN VOLADIZO
- (P) ARRUELA PARA TRANSPORTE DE CANTILEVER
- (I) RONDELLA PER CARRELLO CANCELLO AUTOPORTANTE
- (DK) SKIVE TIL FRITBÆRENDE PORT
- (NL) RING VOOR SCHUIFWAGEN
- (N) SKIVE FOR RULLEPORTVOGN
- (S) BRICKA FÖR FRIBÄRANDE GRINDVAGN
- (FIN) ALUSLEVY ULOKETELINEESEEN
- (PL) PODKŁADKA DO WÓZKA BRAMY SAMONOŚNEJ
- (SK) PODLOŽKA PRE SAMONOSNÝ NOSNÍK
- (EE) SEIB KONSOLALUSE JAOKS
- (LT) POVERŽLĖ GEMBINIŲ VARTŲ VEŽIMĖLIUI
- (LV) PABLĀKSNE KONSOLES NESOŠAJAM RUĻĻU BLOKAM

- (CZ) PODLOŽKA PRO VOZÍK
- (RO) ȘAIBĂ PENTRU SISTEMUL DE CULISARE ÎN CONSOLĂ
- (HR) PODLOŠKA ZA NOSIVO PODVOZJE
- (RUS) ШАЙБА ДЛЯ РОЛИКОВЫХ ТЕЛЕЖЕК САМОНЕСУЩИХ ВОРОТ
- (SLO) PODLOŽKA ZA VOZIČEK
- (TR) MANIVELA TAŞIYICISI İÇİN RONDELA
- (AR) حلبة لولاية الكورول
- (CHN) 悬臂架垫片
- (MAL) SESENDAL UNTUK PEMBAWA JULUR
- (H) ALÁTÉT TOLÓKAPU FUTÓKOSIHOZ
- (IL) חוקית לוגללים לקורול
- (BG) ВЛОЖКА ЗА КОНЗОЛНА КОЛИЧКА
- (KO) 캔틸레버 이송대용 와셔
- (SRB) PODLOŠKA ZA SAMONOSIVU KAPIJU

Art.	L	A	J	K1	K2	M	N	S	CARRIAGE	1pc	📦			CODE
										kg	pcs	kg		
mm											kg	pcs	kg	
RAMP SK 2	189	140	17x25	149	50	20	22	2	SPEED SK	0,4	6	2,4	1700289	
RAMP SK 4	189	140	17x25	149	50	20	22	4	SPEED SK	0,78	6	4,68	1700290	
RAMP SK 6	189	140	17x25	149	50	20	22	6	SPEED SK	1,13	6	6,78	1700291	

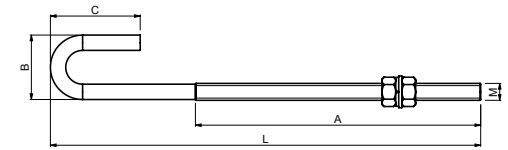
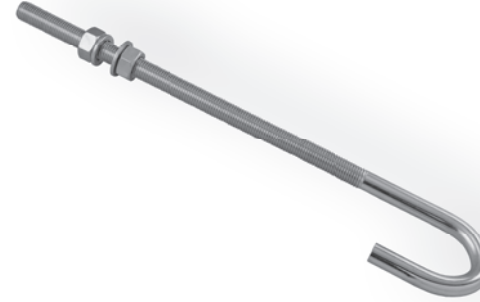

- (GB) FIXING BAR FOR CANTILEVER CARRIAGE
- (D) BEFESTIGUNGSSTANGE FÜR AUSLEGERSCHLITTEN
- (F) BARRE DE FIXATION POUR CHARIOT CANTILEVER
- (E) BARRA DE FIJACIÓN PARA CARRO EN VOLADIZO
- (P) BARRA DE FIXAÇÃO DE TRANSPORTE DE CANTILEVER
- (I) BARRA DI FISSAGGIO PER CARRELLO CANCELLO AUTOPORTANTE
- (DK) FASTGØRELSESSTANG TIL FRITBÆRENDE PORT
- (NL) BEVESTIGINGSBALK VOOR SCHUIFWAGEN
- (N) FESTESTANG FOR RULLEPORT
- (S) FÄSTBALK FÖR FRIBÄRANDE GRINDVAGN
- (FIN) KIINNITYSPALKKI ULOKETELINEESEEN
- (PL) LISTWA MOCUJĄCA DO WÓZKA BRAMY SAMONOŚNEJ
- (SK) UPEVNŔOVACIA TÝČ PRE SAMONOSNÝ NOSNÍK
- (EE) FIKSEERIMISTALA KONSOLALUSE JAOKS
- (LT) TVIRTINIMO STRYPAS GEMBINIŲ VARTŲ VEŽIMĖLIUI
- (LV) FIKSEJOŠAIS STIENIS KONSOLES NESOŠAJAM RUĻĻU BLOKAM

- (CZ) FIXAČNÍ TÝČ PRO VOZÍK
- (RO) BARĂ DE FIXARE PENTRU SISTEMUL DE CULISARE ÎN CONSOLĂ
- (HR) FIKSIRAJUĆA ŠIPKA ZA NOSIVO PODVOZJE
- (RUS) КРЕПЕЖНЫЙ СТЕРЖЕНЬ ДЛЯ РОЛИКОВЫХ ТЕЛЕЖЕК САМОНЕСУЩИХ ВОРОТ
- (SLO) PRITRDILNI DROG ZA VOZIČEK
- (TR) MANIVELA TAŞIYICISI İÇİN SABITLEME ÇUBUĞU
- (AR) قضيب التثبيت لولاية الكورول
- (CHN) 悬臂架固定条
- (MAL) BAR IKATAN UNTUK PEMBAWA JULUR
- (H) RÖGZÍTŐRÚD TOLÓKAPU FUTÓKOSIHOZ
- (IL) מוט קיבוע לגלגלים לקורול
- (BG) ФИКСАТОР ЗА КОНЗОЛНА КОЛИЧКА
- (KO) 캔틸레버 이송대용 고정대
- (SRB) FIKSIRAJUĆA ŠIPKA ZA SAMONOSIVU KAPIJU

Art.	L	A	B	C	M	WASHER	1pc	📦			CODE
							kg	pcs	kg		
mm							kg	pcs	kg		
CLINCH 16	410	300	60	80	M16	RAMP	0,72	12	8,64	1700239	